

# De Vonk

Periodical of  E.T.S.V. Scintilla



- ❖ 3D SELF-ASSEMBLED ELECTRONICS
- ❖ SPAM FILTERING AT SCINTILLA
- ❖ STUDY PROJECT LIÁN XÌ
- ❖ BAKING PIES - PART 1



## How do you create a logic gate using just 24 silicon atoms?

Join ASML as an Electronics Engineer and help push the boundaries of technology.

As one of the world's leading providers of lithography systems for the semiconductor industry, we bring together the most creative minds in science and technology to help produce increasingly cheaper, faster and more energy-efficient microchips.

For the past 25 years, we've been helping to realize Moore's law. Now we want to go even further: to enable the tripling, or even the quadrupling of chip-feature density every two years. That's why we need talented Electronics Engineers. People who can, for example, increase the speed and the precision of our systems integration, and thereby enable future logic gates no bigger than a few silicon atoms. It's just one of the many electronics challenges at ASML. And there are countless more – all targeted at achieving more than Moore's prediction.

If you're up for these challenges, we'll put you in a multidisciplinary team and give you plenty of freedom to experiment and learn new skills. What Moore could you want?

[www.asml.com/careers](http://www.asml.com/careers)

**ASML**

For students who think ahead

# Some words of change

*Author: Koen Zandberg*

**At the time of writing it's already November. Some of you just either failed or passed your exams. The last missing people from the study tour just returned from their long trip to the far eastern land of China. Let's just say I could continue for a while about things that change when summer passes into autumn.**

It has been 2 months since the new board took over the reigns of Scintilla. Not only for me a lot has changed. Scintilla is also slowly changing from a Dutch student association to an international one.

Sometimes presents difficulties, for instance when translating names and terminology. For example, do we have to change 'Scintillakamer' to 'Scintilla Chamber' or do keep it Dutch?

The first few weeks, when the current and previous treasurers were still in China were the hardest. 'No ma'am, he'll back this Monday. Yes, the bill will be paid that same day.' But These months have been a lot of fun too. Getting to visit Shell's headquarter in Den Haag for example. And somehow even the small everyday tasks seem fun, like ordering new chocolate bars and making sure we have all the tea in the world to name a few.

But there are also more serious matters. Some monstrosity called 'afstudeermaanden', a bureaucratic nightmare to compensate students for the work they did. Suddenly you have to decide who should be compensated. Another thing is the 'Bacheloruitreiking', where students who finished their bachelor get their diploma. I was asked to

talk for two minutes to a room filled with 500 people. I'd like to think that kind of got me over my fear of talking to big audiences.

Having to wake up early after a late evening is less fun. Getting to the SK barely in time, making sure everything is up and running, before the first members start coming in. The day reaches its peak around the lunch break. There's always a meeting of some committee and most of the members who need something from Scintilla come to you to ask for it. After that we can go home, unless there's some activity in the evening...

Altogether, keeping Scintilla from going bankrupt and making sure nobody hates us (yet) has been fun up to now and I hope the rest of the year will be as much fun or maybe even better.

Op de koningin, op Scintilla!

Koen Zandberg  
President of E.T.S.V. Scintilla

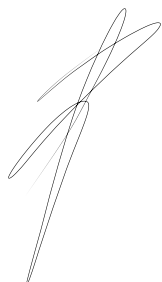

## Agenda

### LaTeX course

December 18th, 2012  
SK, 20:00h

### Shock hobby evening

December 19th, 2012  
Welpzaal, 20:00h

### Christmas diner

December 20th, 2012  
Educafe, 20:00h

### VriMiBo

December 21st, 2012  
Abscint, 16:00h

### VriMiBo

January 11th, 2012  
Abscint, 16:00h



# Colofon

## De Vonk

Periodiek der E.T.S.V. Scintilla.  
Verschijnt 4 maal per jaar in een oplage van circa 600 stuks.

**Jaargang 31, nummer 1  
Augustus 2012**

### Redactie

Tim Broenink, Erwin Bronkhorst, Anja van Gestel, Arno Geurts, Derk de Graaf, Tijmen Hageman, Fieke Hillerström, Peter Oostewechel, Ray Tanuhardja, Marcel Wenting

### Druk

Gildeprint, Enschede

### Redactieadres

E.T.S.V. Scintilla, Universiteit Twente,  
Postbus 217, 7500 AE Enschede, tel: (053) 489 2810, fax: (053) 489 1068

### Internet

vonk@scintilla.utwente.nl (algemeen)

vonkkopij@scintilla.utwente.nl (kopij)

www.scintilla.utwente.nl/commissies/vonk  
(website)

Alle leden van Scintilla krijgen De Vonk gratis toegestuurd.

Niets uit deze uitgave mag worden overgenomen, vermenigvuldigd of gekopieerd zonder uitdrukkelijke toestemming van de Vonk-redactie.

De redactie behoudt zich het recht voor om door derden geschreven materiaal te wijzigen of in het geheel niet te plaatsen. De in de artikelen vervatte meningen zijn niet noodzakelijkerwijs die van de redactie.

ISSN 0925-5427

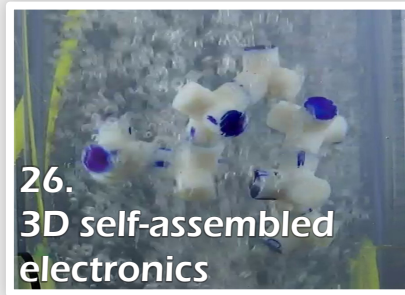

26.  
**3D self-assembled electronics**

Imagine the following scene, taking place in the year 2046: you enter the production facility for high density memory. No cleanroom suits, no vacuum equipment, but tables with liter-sized vessels that are shaken in repetitive motion. The room is silent, only the humming of the vessels can be heard. The vessels contain a milky liquid. In the liquid generation of electronics. Not fabricated by lithography, but grown...



32.  
**Spam filtering at Scintilla**

With the growth of the internet, the number of spam messages that is sent every day increases exponentially. Almost everybody who uses e-mail uses some kind of spam filtering to remove the annoyances of these messages. However, spam is not only negative to the owner of an e-mail address, but it also has some negative consequences for system administrators nowadays. In this article, an impression of the problems that spam...

## And more...

3

Presidential note  
*Some words of change*

6

News  
*News for the Electrical Engineer*

10

New board  
*The 83th board of E.T.S.V. Scintilla*

14

Master thesis  
*Microfabricated swimmers*

18

Junction  
*Robert Fennis*

20

SolarTom  
*The new SolarTom*

22

Bachelor assignment  
*Design of a DDS system*

24

Photopage

As many of you will have noticed, the last couple of months have seen a lot of extra activity in the Scintilla room, followed by a period of relative silence during the first six weeks of this college year. All of this is a result of Scintilla's latest study project, called Lián Xi. Following the success of last year's trip to the U.S., we decided to organize our next trip in the same manner, which meant that every participant is actively...



38.  
Study project Lián Xi

In this 4 part series we will cover some use cases for the Raspberry Pi, both hardware and software. In part 1 of this series, a general introduction to the Raspberry Pi is given. The Raspberry Pi is a credit-card-sized single-board computer developed in the UK by the Raspberry Pi Foundation with the intention of stimulating the teaching of basic computer science in schools. The average Electrical Engineering student is most likely...



44.  
Baking Pies - Part 1

|  |    |
|--|----|
| Main article<br><i>3D self-assembled electronics</i> | 26 |
| Report<br><i>SEED Studio</i>                         | 31 |
| Committee<br><i>Spam filtering at Scintilla</i>      | 32 |
| SKIC<br><i>SKIC camp</i>                             | 36 |
| Study tour<br><i>Study project Lián Xi</i>           | 38 |
| Hobby<br><i>Baking Pies - Part 1</i>                 | 44 |
| Column<br><i>Rightingwrongs</i>                      | 46 |
| Puuzle   | 47 |

## Editorial

### Enhancement

Since time in memoriam people have sought for improvement. Some have sought to improve their own lives, some to improve that of others and some to approach a more abstract goal: to achieve perfection. Many have dedicated their lives to solving the big problems of their age, which thanks to brave minds and mighty brains have brought the world to the state it is in today.

We from the Vonk are proud to be one of the many who try to make the world a better place. Every edition we try to inspire you a bit more, and this is only possible due to the constant search for enhancement. Starting this edition, the Vonk will be published entirely in English and as I'm writing this the t's are crossed and i's are dotted and the final tweaks are made to the new layout we introduced exactly one year ago. Of course, this time we provide a entirely new set of interesting articles for you to read.

First of all, the board will introduce itself through an epic fairytale. This will not be the only introduction, as our brand new SolarTom will explain something about his plans for the next Solar Challenge. The main article will explain how TST sees the future of self-assembling chips. This is not the only article from that chair, as LarsZ has written an article summarizing his Master thesis on microfabricated swimmers. We also have exotic stories from the far east, with an article about study tour Lian Xi and a reportage on Seeed studio, both from Chinese soil. Additional stories include a piece written by SOT on how spam filtering is done at Scintilla and the first of the tetralogy texts on the Raspberry Pi.

This and many more awaits you, so turn the page and enhance yourself with the ideas and experiences of many.

Tijmen Hageman

# News for the Electrical Engineer

*Author: Tijmen Hageman*

## In-body dissolvable electronics developed

Over the years, much focus has been laid onto extending the lifetime of electronic circuits, making them stable and reliable. However a new study takes a completely different approach. The aim is to design circuits which are active for a limited amount of time, after which they are broken down in a controlled way. Researchers at the University of Illinois have designed a new type of electronics, referred to as 'transient electronics'. These circuits consist of silicon and magnesium oxide, encapsulated in silk wrapping. When placed inside a body, the silk layer will dissolve over time by the body fluids, after which the electronics are exposed. Thin layers of silicon can harmlessly

dissolve in these fluids in a limited amount of time, resulting in a fully body-degradable system. Medical implants seem a direct application for this technology, in which it is no longer needed to remove the electronics by means of surgery. First tests have been performed in which chips were successfully implanted in mice and completely dissolved after three weeks. The goal of these circuits was to generate heat to fight off germs, which lasted for a week. Other applications involve the use in consumer electronics, such as in disposable mobile phones.

*Source: medicaldaily.com*

## TSMC wants to produce 450 mm wafers

Taiwan Semiconductor Manufacturing Company Limited (TSMC) has expressed its desire to perform mass production of 450 mm wafers in 2018. Current technology is limited to the use of 300 mm wafers, which is especially used for high-end ICs on small nodes, such as PC processors and GPUs, generally produced using 32 nm technology or smaller. Due to the often lengthy and iterative nature of chip production, it is more cost-efficient to use larger wafers, improving the number of produced chips per unit time of a factory. However, this requires redesigning all machines used for chip production, an investment requiring billions of investment. Initially, TSMC planned to switch to a 450 mm technology in 2015 or 2016, but has delayed these plans.

*Source: tweakers.net*

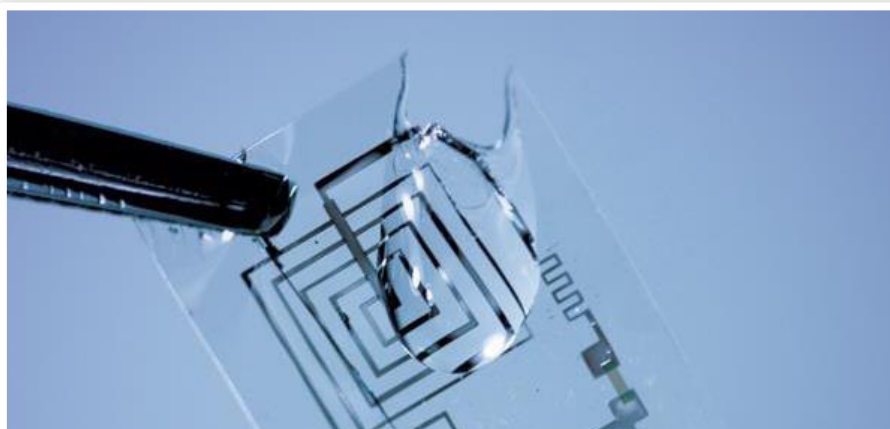

## Moore's law threatened by EUV

Moore's law states that the number of transistors in an integrated circuit doubles approximately every two years. To support this law, the transistor size should be decreased along with this trend. Currently, ASML delivers lithography machines equipped with deep ultraviolet (DUV) light sources, able to lay down patterns as small as 14 nm. In order to scale to even smaller dimensions, extreme ultraviolet (EUV) light sources are needed. However, current EUV sources are only providing five percent of the amount of power needed for an economically feasible wafer throughput, even though the power has been increased by a factor twenty over the past three years. Current throughput is up to seven wafers per hour, while chip makers would like to see this increased to 100 or even 150. The goal for 2014 is to achieve 69 wafers per hour using a 105 W EUV source, while a 500-1000 W EUV source is desired by 2016.

Due to the delay of EUV machines, the current smallest pattern dimensions are around 16-17 nm, while Moore's law predicts a node size of 14 nm.

This October, ASML acquired the company Cymer, which was the largest producer of DUV sources in the world and ASML's main provider. Furthermore, both companies have been cooperating to develop EUV sources. With the \$2.6 billion takeover, ASML hopes to accelerate the development of EUV. Will they catch up with Moore's law?

*Source: eetimes.com*

## Near-permanent data storage developed

Hatashi, in collaboration with the Kyoto University, has developed a method to store data for several hundred millions of years. The technology involves the patterning of fused silica glass, which is known for its high resistance to heat and water. Data can be written by locally altering the refractive index of the glass, which has been achieved by locally irradiating a femtosecond laser. These dots, corresponding to binary ones, can be read out using a general optical mi-

croscope with a signal-to-noise level of 15 dB. Multiple layers can be written by altering the focal distance of the laser. Currently, using four layers, a data density of 40 MB/inch<sup>2</sup> can be achieved, slightly higher than that of a CD. In order to test the durability of the technology, a patterned sample was heated to 1000 degrees Centigrade for two hours with no loss of information.

*Source: hitachi.com*



*Recorded pattern*



*Image obtained with optical microscope*



*Dot image after outline enhancing signal processing*

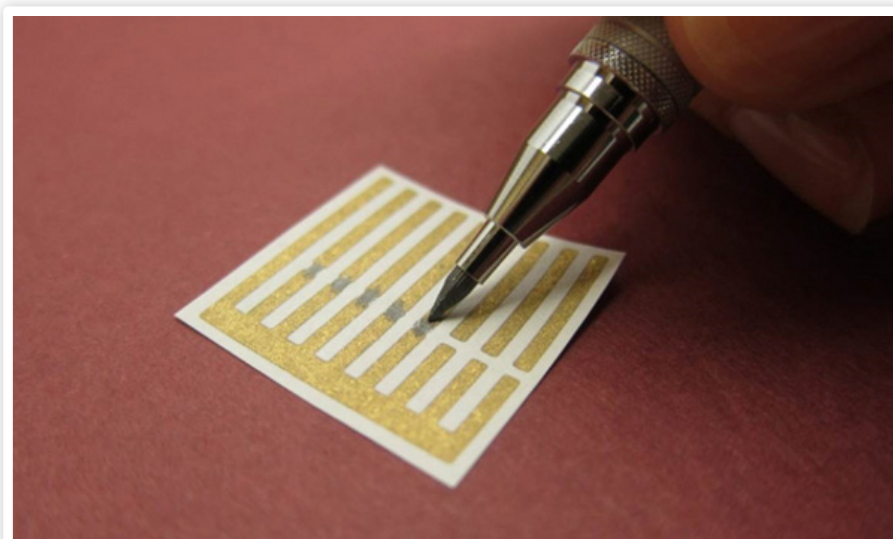

## Drawing carbon nanotube sensors

Sensors made from carbon nanotubes are a relatively new type for sensing harmful gases. Their sensing ability lies in the fact that their electrical resistance changes when gas molecules bind to the tubes. The detection of such hazardous gases can thus be observed by a change in current through a carbon nanotube sensor. Selectivity can be altered by adding metal atoms to the na-

notube walls or by wrapping polymers or other materials around the tubes. There is a problem in the production of such devices, which involves the use of specific solvents, a process which can be hazardous and unreliable. Researchers at the Massachusetts Institute of Technology have found a solution for this problem, by compressing the nanotubes into a graphite-like material and

making pencils of them. This way, creating a sensor is simplified by a process of literally drawing a line on paper between two electrodes. The quality of the resulting sensors is consistent, even with different degrees of uniformity.

*Source: mit.edu*

# Educational changes

*Author: Laurie Overbeek*

A lot is changing at the moment in the educational system. Like what will happen to your student grant? Or to your student travel product? These are all practical examples of changes nowadays. But what will happen to Electrical Engineering for the coming years? What consequences will this have for you? In this article I hope to inform you about the coming changes and how this will affect you.

Let's start off with some good news for some of you. The study delay regulation is abolished!

The ministry of Education, Culture and Science has informed the executive boards of the Dutch universities that the study delay regulation has been abolished effective immediately. At this moment, some of you have paid (a part of) the fine already. If you pay your tuition fee in monthly installments, the UT has corrected this as per October 2012. If you have already paid the full tuition fee for the academic year 2012-2013 either by bank transfer or direct debit, you are eligible for a refund of the surcharge (raised part) of the statutory tuition fee. If you have any questions regarding this matter you can contact the student services in the Vrijhof building.

## Bachelor's-before-Master's rule

First for all of you who have never heard of the Bachelor's-before-Master's rule I will introduce this shortly. This rule states that you have to finish your bachelor's degree before you can start your master program.

The aim of the Bachelor's-before-Master's program is to encourage students to make a well founded decision when choosing their master's program. It also makes it easier to switch universities to follow a master program elsewhere. Also the Bachelor's-before-Master's rule means that all students can start their Master's program with a clean

---

*“Let's start off with some good news for some of you. The study delay regulation is abolished!”*

---

slate and without the added burden of having to complete Bachelor's courses. Now this can be an advantage but also a very big disadvantage if you need to complete only a few remaining courses. If you have any questions about your study plan and the effect of this rule on your study please go and have a chat with the study advisor of Electrical Engineering (Thea de kluijver).



This rule applies to all students from 1 September 2012. From 1 September 2012, Master courses completed before 1 September 2012 can be transferred to the Master's program at the student's request upon completion of the Bachelor's program. Because of this rule in the academic year 2012-2013 Bachelor students can progress to a Master's program on a monthly basis.

## Student grant

For all Dutch students a lot will change regarding the student grant. The new government's agreement states that all new students starting a Bachelor's or Master's program will not receive a student grant any more starting 2014. This only applies for the basic student grant; all additional student grants you might receive now will remain present in the future. The student grant will be replaced with the student loan system. This system allows you to loan money with a relatively low interest rate. You will have to pay your loan back when you have finished your education and when you have found a job.



## Student travel product

The new government agreement contains more bad news for students. The student travel product will stop to exist in 2015 if the plans of the politicians won't change again before 2015. The student travel product will be replaced with a discount travel card. All in all it will be more expensive for you: no student grant and no student travel product will mean a raise in cost for you.

## Electrical Engineering

As many of you have already noticed this is the first year that all freshmen students have modular education during the first three quarters. Next year the second year

classes will not be taught in modules. First year classes will be modular in 2013 as well. Second year courses will be modular for the first time in 2014 and third year courses

---

“As you can see a lot of changes are coming up in the next few years.”

---

will be given in a modular way in 2015. Of course the university has transition rules for people who have to retake a course. A solution will always be found for you. You will not have to follow a whole module if you just miss one course of that module. Please contact the student advisor for the best solution for you!

As you can see a lot of changes are coming up in the next few years.

If you want to be involved in a nice way in the organization of the study Electrical Engineering, or if you want to improve the education for the next generation (or even of courses you still have to take yourself) you might want to think about joining the StOEL committee. If you want to join or if you have questions about this committee, just ask a member of the committee or the board of Scintilla about StOEL.

## Complaints about the education?

If you have any complaint about the educational changes or the way a course is given, contact StOEL (StudentenOverleg ELEktrotechniek, this is dutch for Student Consultation Electrical Engineering). In this committee of Scintilla, other students try to make the education better by transferring the complaints straight to the right person or department at the University of Twente.

In StOEL, students of different college years are present to make sure all complaints from the lectures are heard. You can complain about almost anything: bad study material, a stuttering teacher, a chair during the lecture that hurts your back and a strange question during the exams:  
StOEL likes to hear from you!

You can reach StOEL by e-mail, via the address [stoel@scintilla.utwente.nl](mailto:stoel@scintilla.utwente.nl) or you can fill out the complaint form at the website [www.scintilla.utwente.nl/nl/stoel/complaint](http://www.scintilla.utwente.nl/nl/stoel/complaint)

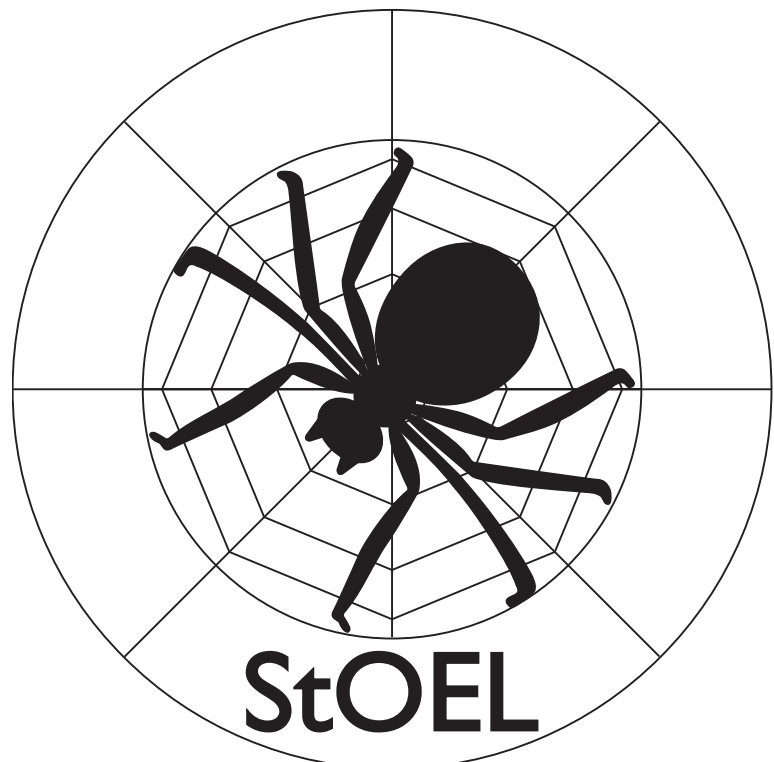



# The 83<sup>rd</sup> board

## Tale of the five knights

*Author: Koen Zandberg  
Photo's: Eerde Bruining*

Ladies and gentlemen, boys and girls gather around while I tell you a story. A story about the epic quest of the brave Knights of the round square table looking to defeat the big evil monster of Change that endangers all of the students (insert dramatic sound) TOM TOM TOM...

When news was received at scintilla, the great bastion of technical knowledge situated in the eastern end of our little country, it was immediately brought to the attention

of the four wise rulers of this bastion. These rulers, who were the eighty-second generation of wise rulers that Scintilla has had, realized that the big evil monster of Change, quickly dubbed the Bemoc, had to be stopped and controlled.

In their infinite wisdom they decided to send one of their most trusted knights, Baron Koen Zandberg of castle Colmsgate. Koen was a former landowner from a more western county. When he was summoned

over a secure shell connection he quickly traveled to the bastion of Scintilla using the iron horse summoned by the New Sorcerer, also known as the NS.

When baron Zandberg presented himself before the four wise man, he was sent on a quest of epic proportions. His goal, to control the Bemoc by any means.

He quickly found out that, in order to control the Bemoc, he needed a mighty weapon created by the most esteemed tin-smiths



**President**  
**Koen Zandberg**



**Secretary**  
**Luuk Oudshoorn**



**Treasurer**  
**Mattanja Venema**

and infused by the mighty power of the lightning bolt. He could use this weapon to travel the dangerous path known as Route14+ and control the Bemoc.

In order to find such a mighty weapon, baron Zandberg set out to the most esteemed purveyor of mighty goods that he knew. He wanted to travel to the STORES, to meet one of their members, the purveyor of goods and mighty weapons, Karim Kok.

Karim was born in a little village in the far north, called Oosterwolde. When he reached the age of eighteen, he decided to travel the world in order to learn to harness the mighty lightning bolt. After traveling to Delft and Eindhoven, he finally arrived in Enschede. He is now the sole controller of the finances of the STORES.

Baron Zandberg set out at sunrise the next morning in order to travel to the STORES. When he reached the castle where the STORES was situated he found that the gates would not open, for he had arrived before the eighth hour of the day. Luckily for him, he met there with Luuk Oudshoorn.



Luuk Oudshoorn, also known as the sir Writesalot, is a noble knight from the barbaric place known as Zwolle, a bureaucratic town that is famous for its border control offices for the northern barbaric regions Groningen, Drenthe and Friesland. From here he came to Enschede where he disco-

vered that the pen is indeed mightier than the sword. However, you should use a very large and pointy pen.

Using the power of his mighty pen, sir Writesalot assisted our baron in the creation of a demonic contract known as a gebouw-pasformulier. As soon as this contract was sealed Koen could open the door by simply walking up to it.

Once inside castle Zilverling, Koen discovered another problem. Due to the exorbitant prices the NS charges for transport on the iron horse, he did not have any money on him. This was a problem, for Koen knew that in order to purchase a mighty weapon from the STORES, he needed money.

But luckily for Koen, Mattanja was present. Mattanja Venema is a former barbarian from the high north. He came from a small village in Groningen, where his name, officially Mat-Tan-Ia, means "He who counts stuff". He is now not only in charge of the monetary supplies of Scintilla, which luckily for him need lots of counting, but also an accomplished tinkerer who in his spare time



**Commissioner external affairs  
Tim Broenink**



**Commissioner education  
Laurie Overbeek**



**Administrator  
Karim Kok**

tries to organize scrapheap events.

So Koen's financial problems could be solved quickly. He was now finally able to purchase the most awesome weapon of technical nature, the mighty hammer. Made from the finest metals with actual electrons in it, it was certainly a weapon to be reckoned with.

Now armed with not only knowledge, but also with his mighty hammer, Koen soon set out to beat the mighty Bemoc, taking with him sir Writesalot and Mat-Tan-Ia to assist him in his quest. He traveled to the heart of the problem, ready to meet the beast and to slay it.

The last problem our baron had to face before he could face the Bemoc was the army of bureaucrats that tried to protect it. They were greatly outnumbered, for they were only three man, facing an army. However, as is always the case, fortune favors the bold.

Sir Broenink II came to assist them. Tim Broenink is a second generation tinsmith from one of the local villages. He had con-

tact with most of the technical lords and mercenaries, and convinced them to help Scintilla in their quest. For they all had a common goal, to increase the technical knowledge of the world and to harness the power of the electron.

So when sir Broenink II brought down the corporate forces on the army of bureaucrats, the small party of brave knights could slip through the enemies' lines and continue towards the Bemoc.

They met the Bemoc in a battle of epic proportions. I could try to describe it to you, but words are not enough to capture the bravery and might of our knights. However, try as they might, the knights could not defeat the Bemoc.

When our knights had lost all of their hope of defeating the monster, they were saved. Just returned from a long journey from a faraway land, Lady Overbeek had returned.

Laurie Overbeek was a brilliant lady from the rural village of Losser. She had just traveled to globe in order to increase her

knowledge of the art of learning. Specialized as she was in the workings of our educational system, she had discovered the weak spot of the big evil monster of change.

With one crack of her mighty whip, she drove the Bemoc back. "Down boy". After some cruel and unusual punishment at the hands of lady Overbeek the monster submitted. Now, with the Bemoc finally controlled and contained, the team of brave knights could return victorious. And they could protect Scintilla for the year to come.



*l.t.r: Commissioner external affairs Tim - Secretary Luuk - President Koen - Treasurer Mattanja - Commissioner education Laurie*

# Microfabricated swimmers

Transducer Science and Technology Group

*Author: Lars Zondervan  
Supervisor: Leon Abelman*

Suppose, just suppose for a minute that you drank a lot of beer during a party... You are barely able to crawl back home and you crash on your bed. You know that the alcohol will make short matters of your brain cells and your liver is working like crazy to get the alcohol out of your blood. Why not help your body in these hard times? You can drink a glass of water to counter the dehydration effect of alcohol, but what you really want is to actively help your body handle the alcohol and minimize the damage. What if you could inject a small robot into your blood stream to take care of this!



This is of course a ridiculous situation: we don't want to encourage people to drink more alcohol. But the idea of helping the body cope with physical problems at a cellular scale isn't new. Administration of

drugs is as old as the hills. Surgery and physical treatment is used to treat trauma or disease on a physically larger scale. However we can see that there is a gap in dimensions. Were medicine and dialysis work on

a single nanometer or even ångström scale, surgery works on millimeter scale at best. What about the micrometer range? In this size range there are no or few medical instruments available at the moment. Yet the body itself does have a lot of 'tools' at its disposal: micro-organisms. It is estimated that microbes account for 1-3% of the total mass of a human body. These micro-organisms support a lot of vital body functions, especially in our gastrointestinal tract. What if we could fabricate artificial micrometer size structures which could be handled and utilized just like surgical tools and at the same time functionalize them just as we can functionalize medication? This would breach the gap between macroscopic tools and microscopic (chemical) treatment. With this idea in mind I spend my master research on a preliminary study towards microfabricated swimmers and compared these with nature's own micrometer swimmers: bacteria. My research is focused on the controllability of both these structures.

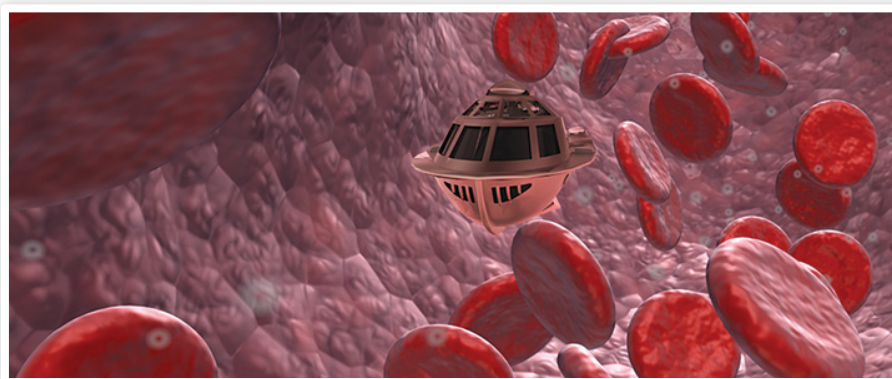

*Figure 1: In the movie/book 'Fantastic Voyage' a submarine (shrunken to microscopic proportions) is injected into a human body. Was this story based on Feynman's famous lecture 'There's plenty of room at the bottom'? In this lectures Feynman envisioned not only our current state of IC technology, atomic force microscopy, nanotechnology (just to name a few) but also a 'swallowable surgical robot'. This robot would be controlled externally by a physician to perform tiny medical procedures.*

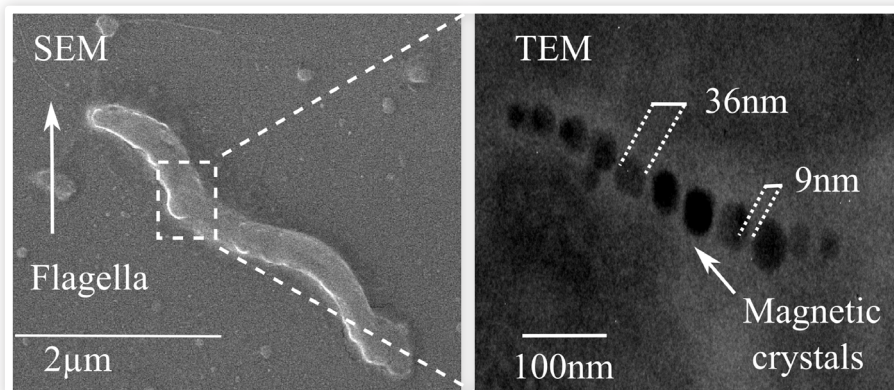

Figure 2: Scanning Electron Microscopy (SEM) image of the MTB (left) and Transmission Electron Microscopy (TEM) image of the magnetic crystals of the MTB (right). Images made in the MESA+ Nanolab.

Yes, you read that correctly: both the direction of motion of the microfabricated swimmers as the direction of motion of bacteria has to be controlled in order to compare the controllability of these structures. But how can you control bacteria? For this purpose the bacteria *Magnetospirillum magnetotacticum* has been cultured. This magnetotactic bacteria (MTB) grows a chain of magnetic crystals in its body to sense the earth magnetic field. However when put in an external magnetic field this MTB will rotate such that this chain of magnetic crystals aligns along the direction of the external magnetic field. As the MTB has a flagella (tail-like appendix) to propel itself and it's alignment can be controlled by supplying a magnetic field with adjustable orientation the bacteria can be literally steered around in a liquid solution (for instance: through micro fluidic chips or capillaries).

When thinking about micrometer sized structures who, just like bacteria, move through a liquid, a few considerations are of vital importance. The first consideration is the fact that due to the extremely small size of these structures surface effects are far more dominant than bulk effects (i.e. drag forces will be far more dominant than inertia). This directly leads to our second consideration: if surface forces (drag) are so dominant it's impossible for a structure of this size to be fuel driven. The extremely small volume for fuel storage can never drive some sort of motor which has to overcome these drag forces. The needed energy density of the fuel would be tremendous. This means that the microfabricated swimmer has to harvest it's energy from it's surround-

ings: just like bacteria do. They are actually swimming around in their fuel!

For this purpose micrometer sized catalytic structures are fabricated using surface micromachining techniques in the Mesa+ Nanolab. These structures acts as catalytic 'platinum-hydrogen-peroxide motors'. When hydrogen peroxide ( $H_2O_2$ ) comes in contact with a Pt surface it's natural decomposition into water ( $H_2O$ ) and oxygen gas ( $O_2$ ) is greatly accelerated. This catalytic reaction is used to propel structures with one Pt side through a liquid. A different configuration proposal uses an Au-Pt structure and claims that a redox reaction at both metal surfaces with the peroxide delivers the propulsion. The mechanism behind this propulsion is still under debate and at least ten different mechanisms have been presented in literature. We choose for a Au-Pt micromotor with the a Pt surface and a Au surface at the top side of the structure as this will allow us to distinguish between a decomposition reaction or a redox reaction (as they differed in dynamics). A Co/Ni element was incorporated to allow the application of an external magnetic torque. Different shapes and sizes were fabricated for the sake of comparison.

However, when the Microfabricated swimmers (MS) came back from fabrication their capacity to swim was almost completely absent. The catalytic reaction was definitely present (oxygen bubbles were forming) but due to the

size of these bubbles they were not re-absorbed into the liquid and, even worse, stuck to the surface of the MS. All attempts to make the surface of the MS more hydrophilic (as to inhibit these bubbles to attach to it's metal surfaces) failed miserably.... This was most likely why no publications on catalytic micromotors fabricated using this fabrication method were found. Due to the hydrophobicity of the metal surfaces, these structures couldn't supply a continuous catalytic reaction and hence can't propel themselves. Well, that's swell. After months and months of work, those darn things don't work!?

And how am I going to graduate now? Damn physics!

This was the moment Leon Abelmann advised me to focus on what DOES work instead of what DOESN'T and try to bundle these results into a coherent research. If these MS don't swim it's hard to compare their swimming with MTB. However it's still possible to characterize the controllability of both the MS and the MTB as they both have magnetic material in their structure. So instead of comparing the motility of these kind of structures I had to focus on their controllability.

When you want to characterize controllability you want to know what the maximum speed of rotation is: how fast can you re-orientate your structure. This rotation speed is the result of a magnetic torque you apply

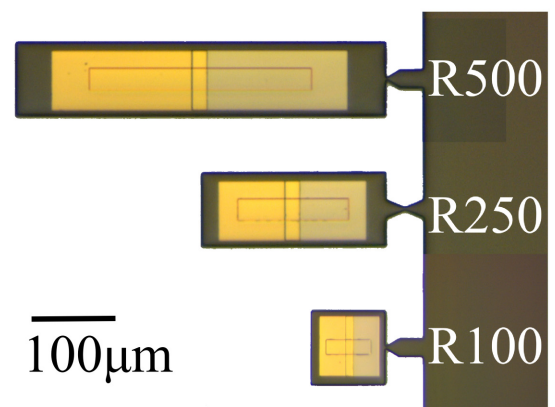

Figure 3: Microfabricated Swimmers (MS) of rectangular shape and different sizes. These small holders are made of SiNi. A strip of CoNi is deposited on these holders which is covered with a Au layer on one side and a Pt layer on the other side. After fabrication these structures are still attached to the substrate but can easily be released by breaking the small notch (under a microscope).

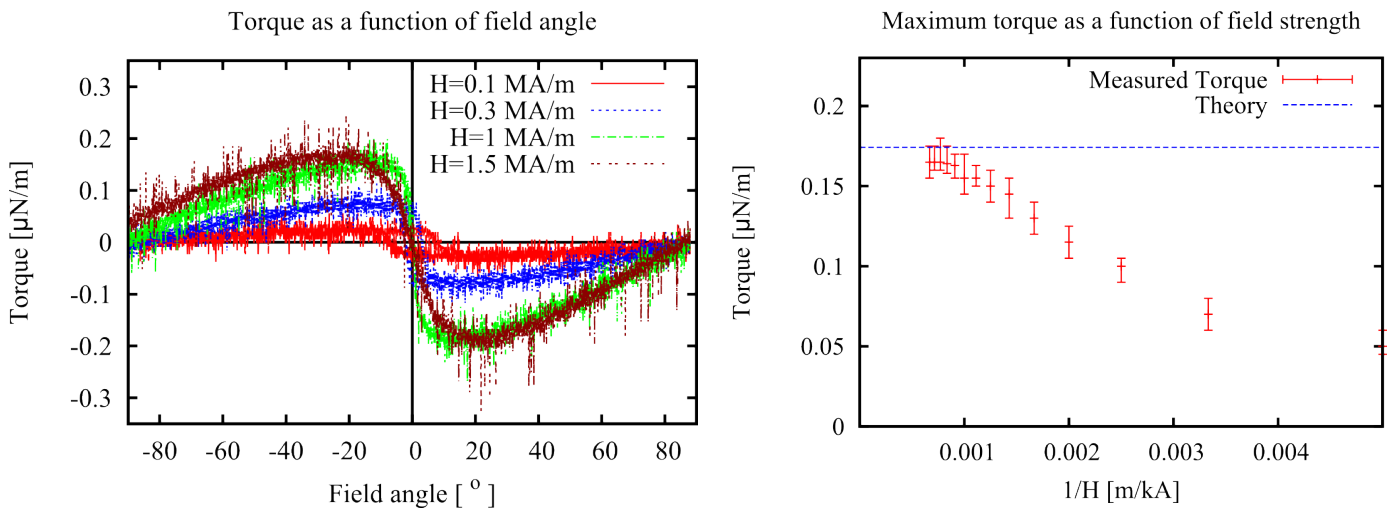

Figure 4: Measured Torque as a function of the angle between the direction of the magnetic field and the direction of the MS for different magnetic field values (left). For weak magnetic fields, hysteresis is visible (the red loop). When the maximum measured torque for different magnetic field values is compared with theory we see that for magnetic field values lower than the saturation magnetization of the magnetic material a lower torque is obtained, while for field values higher than this value the torque doesn't increase anymore (right). Note the inverted X-axis.

to the structure or bacterium and the drag of the liquid on this structure. At a certain speed of rotation these forces balance and you find your measure of controllability. The torque we apply to the MS can be calculated from the shape of the magnetic filament: the difference in energy magnetizing this MS either along its length or along its width is the magnetic anisotropy energy.

As we know the shape (from the mask) and thickness (from the deposition process) we can calculate this difference in energy. Furthermore, because these MS structures are still attached to the substrate after production the torque on these structures can be directly measured using a Torque Magnetometer (TMM). A TMM is generally used to characterize thin layers of magnetic

materials used for data storage but is now used to verify my calculations. If we want to compare the torque values found for the MS with the torque values we can apply to the MTB we want to calculate the magnetic anisotropy energy of the chain of magnetic crystals in the MTB (see the TEM images). As this geometry is a lot more complex than the geometry of the magnetic material in the MS a Finite Element Model (FEM) is constructed. Although in literature (in a paper from the 60's!) an algebraic solution of a chain of dipoles was proposed for these kinds of problems. However approximating magnetic spheres as dipole (magnetic points) seemed like a course approximation. As they couldn't have verified their formula with FEM simulation at that time it seemed worth checking their solution with my own FEM simulation. I wrote a script in which I could set a range of parameters I wanted to vary and around a few hundred different geometries were generated and solved. This is needed as it seemed there is a large spread in the number of magnetic crystals in each bacterium and the distance between these crystals (as obtained from the SEM and TEM images). When these results are compared with the algebraic expression for chains of magnetic dipoles these values overlapped fully with the simulation! Apparently the closed form expression from a paper 60 years ago is an exact solution of my FEM simulations

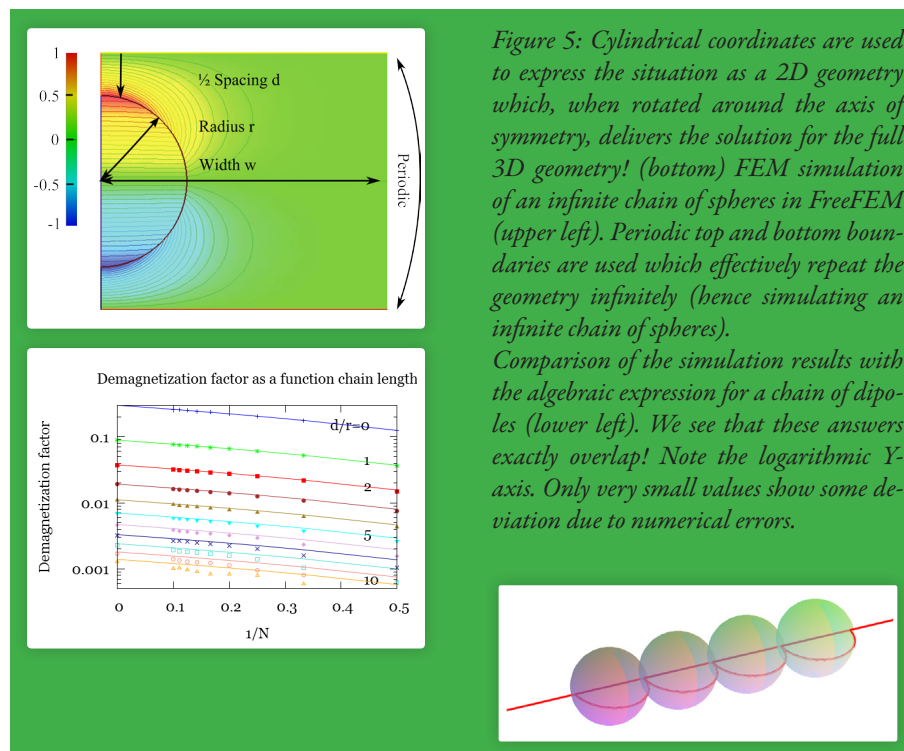

Figure 5: Cylindrical coordinates are used to express the situation as a 2D geometry which, when rotated around the axis of symmetry, delivers the solution for the full 3D geometry! (bottom) FEM simulation of an infinite chain of spheres in FreeFEM (upper left). Periodic top and bottom boundaries are used which effectively repeat the geometry infinitely (hence simulating an infinite chain of spheres). Comparison of the simulation results with the algebraic expression for a chain of dipoles (lower left). We see that these answers exactly overlap! Note the logarithmic Y-axis. Only very small values show some deviation due to numerical errors.



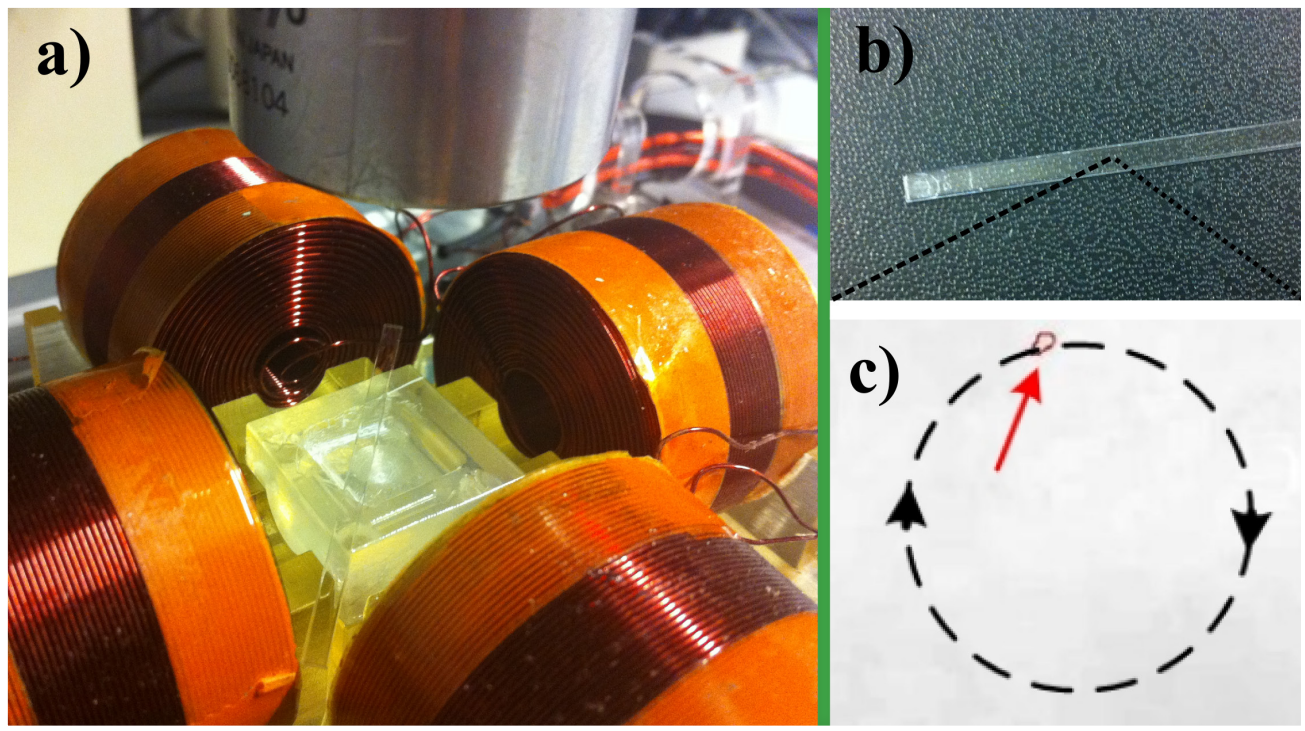

Figure 6: Control setup uses four coils to generate a magnetic field in with a certain direction in order to apply a magnetic torque on magneto active bacteria (a). The bacteria are encapsulated in a closed capillary tube with a high of 0.2 mm (b). This setup is

used to steer bacteria in circles, which can be seen through a microscope (c). The circle these bacteria describe is can be decomposed in a translational and a rotational motion and can be used to find the speed of rotation of these structures.

Setup build by Jasper Keuning, experiments done by Marc Pichel and Islam Shoukry Mohammed Khalil (Robotics and Mechatronics group).

of a fairly complex geometry. And at that time they didn't have the means to verify their formula by FEM simulation... Very impressive! Sometimes it seems that trough the lack of computing power mathematic understanding of complex problems is far better developed in old papers.

Now the torque values for both the MS and MTB are calculated and either measured or simulated, only the viscous drag from the liquid on these structures needs to be calculated to complete the model. This can be done relatively easy by using rotational drag coefficients. These drag coefficients have been calculated for objects of different shapes for either translational motion or rotational motion. This is very well described in 'Random Walks in Biology' by H. C. Berg in which he described the motion of bacteria (for which he also needed to calculated their drag coefficients).

From these calculations, measurements and simulations I can conclude the torques we

can apply to the microfabricated swimmers (by calculation and measurements). We also saw that the closed form expression of a chain of dipoles can be used to accurately calculate the torque we can apply to the magnetic bacteria (verified by FEM simulation). By calculating the drag of both the MS and MTB and combining this expression with the found torque values we can calculate the speed of rotation of both the MS and MTB!

Although I already graduated, the maximum speed of rotation of both the MTB and MS is now being measured by other students. The initial measurements on MTB show that the measured rotational speed falls in the range predicted by my calculations.

Even though my initial results were very disappointing (they don't swim!!) by shifting my focus still some nice measurements and conclusions could be made.

Although I doubt this research will help us

manage our hangover in the future, understanding and illustrating the dynamics of micrometer sized structures in a liquid can make a valuable contribution. And personally I really like how in one assignment I had to work in the fields of fluid dynamics, material science, magnetics, FEM simulation, micro-biology and micro-technology! Research towards micrometer sized self-propelled structures continues at the TST group and if you have an interest in either micro-fluidics, micro-technology, micro-biology, chemistry, material science, magnetics, or generally kick-ass experimental research feel free to join us!

# Junction

*Author: Tijmen Hageman*

**To many among us the name Robert Fennis will not sound unfamiliar. It made me feel old and very not Scintillia like when I found out about this, as I did not know him. In a state of anxiety, whilst counting my grey hairs, I decided to hurl myself in the world of second-year students in order to obtain information. Starting with... yes, of course... Robert Fennis.**

Where do you come from?

I'm from Loosdrecht, which lies in the vicinity of Hilversum. It's a rather small village which actually isn't that noteworthy. At the moment, I'm living on the university campus, at the Matenweg. During weekends, I regularly visit Loosdrecht.

How would you describe yourself?

That's a good question. I think I'm sort of a chaotic scientist. I'm doing a thousand different things and I find everything interesting, resulting in my room being one big mess. Not only my room, but also my mind and homework, if I even get round to doing that.

I'm also busy with music and sometimes EE-projects, but that depends on the moment. In secondary school, I was also busy doing many things which I've had to give up because I don't live there anymore. For instance, I've done ballroom dancing and

---

**"I think I'm sort of a chaotic scientist."**

---

sky-gliding. I've considered doing the latter in Enschede, but it often takes up complete weekends and is very expensive. Furthermore I've played volleyball. Things I'm still doing include drawing, drumming and playing the guitar.

And what have you been doing since you started studying?

Last year I did rowing and now I'm doing fitness as well as playing in a band. The latter I'm doing together with three other students, who study Biomedical Engineering, Industrial Design Engineering and Computer Science. The music genre we play varies, but it can best be described by progressive rock. We write much of the music ourselves, as we prefer that over covering other bands.

What are your pursuits on the field of EE?

At the moment, I'm especially busy working on Scintilla's soldering course, which is being organized by the SPARK-committee. Originally we started at the end of the previous college year designing a class-D audio amplifier. With SPARK, we intend to assist concrete, larger projects which are comparable to the mid-P and end-P projects. We want to create a hobby community in which people stimulate each other and ideas will be exchanged. We also want to motivate people to work on those projects in a serious manner, such that real progress can be made. We thus also encourage the development of documentation and the use of deadlines. As we're busy organizing the soldering course, it currently has a lower priority. However, we have developed a lot of new ideas for hobby projects for after the course has been completed.





Are you active within Scintilla, other than for SPARK?

Yes, I'm a starting member of the Borrel. Furthermore, I think I'll remain active at Scintilla for a while longer.

What do you like most about life as a student?

Especially the fact that the atmosphere is very realistic over here. Normally, you're always dealing with parents or siblings who are nagging or something like that. Here at the university, everyone tries to make the most of it. You're only dealing with enthusiastic people, which results in a calm and relaxed atmosphere. You can really be yourself out here; nothing is stopping you and everyone is social.

Why have you chosen to study EE?

At first I wanted to study Applied Physics or Aerospace at the Delft University. I actually did not even know about the existence of EE. My parents thought I should widen my view for a bit. When I came across

Electrical Engineering, I had one of those light-bulb moments. When I was young, I liked all those switches, lamps and those boxes full of experiments. Later on that enthusiasm disappeared because I didn't understand anything of it anymore. When I found this study, the practice of designing

---

*"When I suddenly saw electrical engineering, I had one of those light-bulb moments."*

---

and building my own projects was close at hand which is actually something I've always been searching for, but never found until now. I think I've always been interested in electronics. And when I came over here, I directly knew Twente was a better fit for me than Delft. The latter is much more urban, while Twente offers a more natural environment.

What are the positive and negative parts of the study?

The best part is the fact that you learn to construct something functional. So in fact the hobby part, but then on a more serious level which will eventually be used at a job later on. Preferably, I'd like to develop complete products or else work on a part of it if the project gets too big. The worse part of EE is... (laughs) Telematics Systems and Applications! There actually is nothing I don't like about the study, except for the mandatory seminar of that course. For the rest, I think it's awesome.

What are your future plans?

Well, in any case I'm finishing the study. I don't think I'll finish the Bachelor in three years, but four years should do the trick. I'd like to become a product engineer later on, so I don't think the research direction will be suited for me. Also, I'm interested in becoming a teacher. Maybe I'll follow a minor Didactics, which allows me to teach physics or mathematics at a secondary school level.

# The new SolarTom

*Author: Tom Kooijman*

**Late 2011:** After having studied nominally for three years its about time to seriously slow down the studying and do something else. An information lunch from the Scintilla board convinced me that the board is not for me. I don't want to learn management. I don't want to learn how to negotiate. I want to learn how the theory from the EE courses can be converted to practical applications. I want to learn how to work hard, seriously hard and to get a tangible end result. Solar Team Twente has been in the back of my mind for a while now so it was about time to look a bit further into this option. The longer I spent on their website, looking at pictures and videos, reading blogs, the more interested I became. And that's how it all began.



The first information on the solicitation procedure for Solar Team Twente is on the website at the beginning of February. The solicitation will take three rounds, the first being a general conversation, in which you don't have to indicate what position you'd be interested to fill. So I sent a polite solicitation mail in which I introduce myself and talk about wanting to do the electronics for the 2013 team. Meanwhile I'm still busy with the last courses of the third year. I slide through the first round. For the second round I have to write about a practical assignment I once did. My B2 assignment comes in handy here as I'm not a fanatical hobbyist and have almost no other references.

In the middle of May I'm told I've also made it through this round. In the last round I have to fill out a personality test which will be discussed at the end



of May. Another week passes before I receive the news that I also got through the last round and am now part of Solar Team Twente 2013!

And thus I became the new SolarTom.

Meanwhile its October and the new team has been hard at work for more than a month to prepare for the World Solar Challenge 2013, which is held in October 2013 in Australia. The first period, as with any project, is spent planning, looking for things to improve, listing demands and more typical project related activities. Besides that we visit a lot of companies and get personal tours of which LEX (committee lectures and excursions) would be jealous.

The other part is almost, but not entirely, completely different than a regular project. At first the hours: every day from eight thirty to half past five and regularly sneaking back in the evening.

The team does not consist of three to four people who all follow the same study, instead there are 17 boys and girls from both the Saxion and the UT. Save for Elmar they all do something different from me: Aerodynamics, Mechanics,

getting sponsors, manage and others things of which I have little knowledge. Yet, I do have to work with these people, we consult each other and make sure that in the end there is a working solar car.

Moreover I'm not working on one project at a time, but on multiple areas at the same time. Eventually they all have to be finished thus I have to plan my time carefully. What areas I'm currently working on will be the subject for next time. Not only because it would make this article seriously too long, but also because I'm not allowed to reveal everything just yet.

We've also had the first taste of the World Solar Challenge: on the 23rd of September we entered in the European Solar Challenge. Of course we used last year's solar car, because our car is only a couple of sketches at the moment. We achieved a respectable second place with a car not designed for the challenges of that particular race. A slalom and a figure of eight are not nice things to do with a big, broad three-wheeler. Then again the car showed its quality in the 500 m sprint when it managed to pull up to 100 km/h!

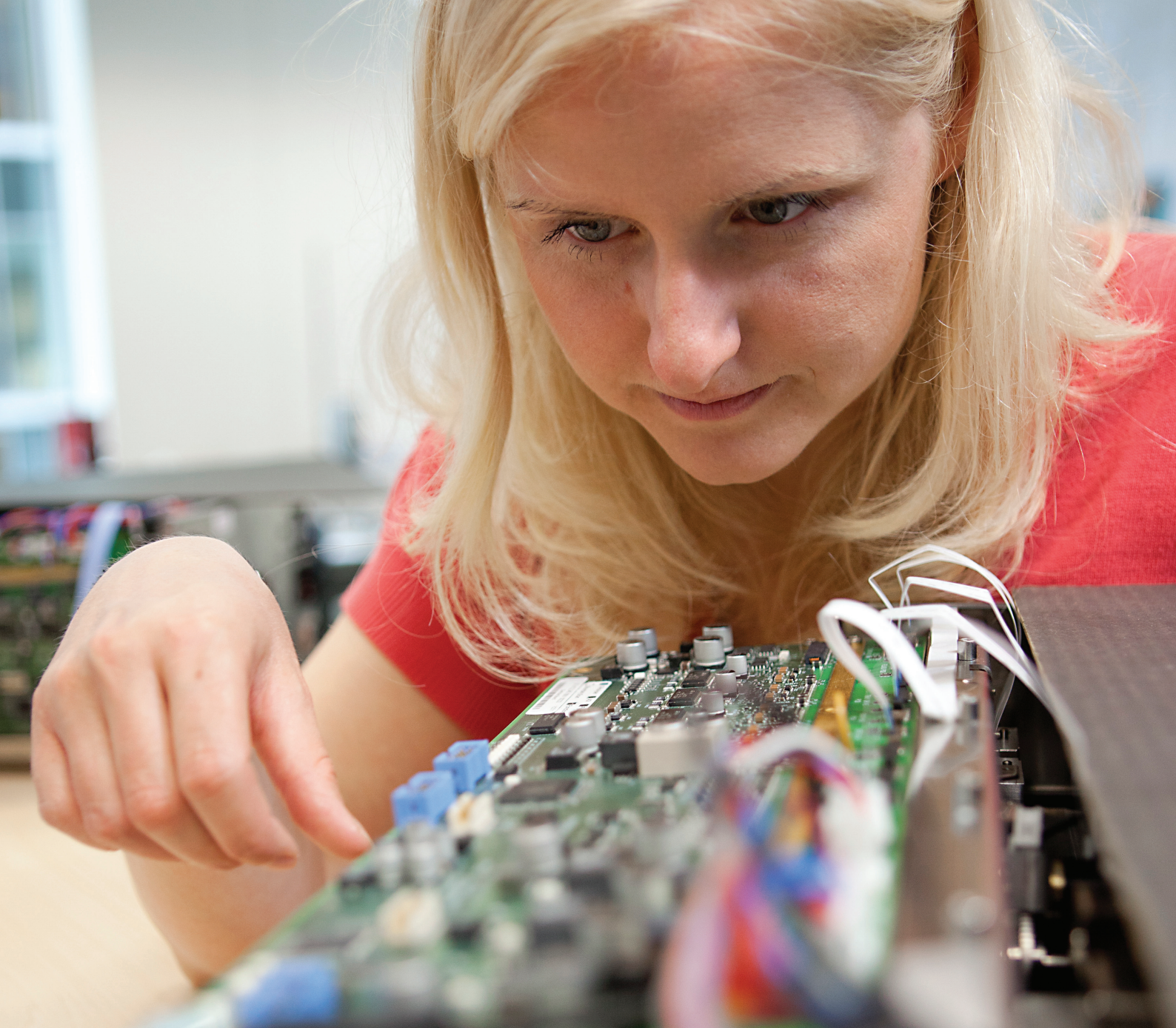

## Put yourself at the forefront of meaningful innovation

Philips is a diversified health and well-being company, focused on improving people's lives through timely innovations. As a world leader in healthcare, lifestyle and lighting, Philips integrates technologies and design into people-centric solutions, based on fundamental customer insights and the brand promise of "sense and simplicity".

### Grow with Philips

Join an innovative company in health and well-being that makes a real difference to people's lives. We challenge and empower you to make the most of your talents while working in multidisciplinary and international teams. You will be surrounded by passionate, insightful colleagues who share your drive to create superior customer experiences. Our growth depends on yours, so we'll support you with career opportunities that will let you accelerate your growth in directions to which you aspire.

Visit our website and grow your career in a company that values the interaction between technology and people.

[www.philips.nl/carriere](http://www.philips.nl/carriere)



Join 120 years of innovation

**PHILIPS**  
sense and simplicity

# Design of a DDS system

Author: Maikel Huiskamp

In many electronic systems an electronic oscillator is needed for clocking of the system or as a time reference. These oscillators can have many forms such as a collpits oscillator, ring oscillator or an LC oscillator. Much time was spent to improve the frequency resolution, spectral purity and stability of these analog oscillators. Since 1971 there is a digital approach for making stable oscillations called DDS. DDS stands for Direct Digital Synthesis. A DDS is able to create an arbitrary waveform operating at an arbitrary frequency within its specifications. Since a DDS is a digital system its output can be changed easily, this in contrast to the most commonly used oscillators which generate only one waveform at a certain frequency.

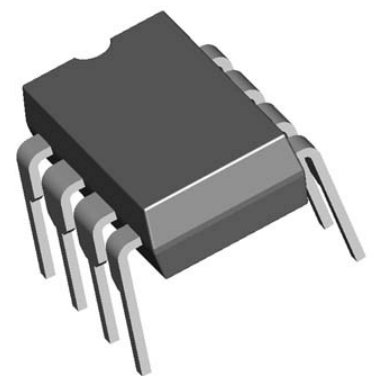

For my bachelor assignment at the ICD group I had to design a DDS system that could be used for beam forming. Beam forming is a technique that uses interference of multiple transmitters to focus the power of the transmitters in one direction. For this the DDS system should be able to create signals with a variable time delay. Beam forming is often used in radar systems. Another technique used in radar systems is chirping. A chirp is a signal that changes its frequency over time. This was also a demand for the DDS system.

The specifications for the DDS system are as follows. The system should support:

- A time delay between 3ps and 1ns with 10% fault margin;
- A configurable output frequency between 62.5 and 125MHz, and;
- Chirp capability

A DDS consists of a couple of parts including a phase accumulator, a phase-to-amplitude converter and a digital-to-analog converter. The phase accumulator is the

component that determines the output frequency and the frequency resolution. The phase accumulator exists of a counter which sums a constant value with its previous output value. The output of the phase accumulator is a modulo  $2^N$  saw tooth waveform where  $N$  is the size of the adder. This saw tooth waveform corresponds to the phase of the signal. The saw tooth waveform also determines the frequency of the output signal, which is given by

$$F_{\text{output}} = \text{FCW} * F_{\text{clk}} / 2^N$$

where FCW is the frequency control word,  $F_{\text{clk}}$  the clock frequency of the system, and  $N$  the number of bits used for the phase accumulator. The phase accumulator can thus be seen as a variable clock divider. The minimal frequency of the system can be found by making the FCW equal to 1, which is also the frequency resolution of the system. See figure 1 for the phase accumulator implementation.

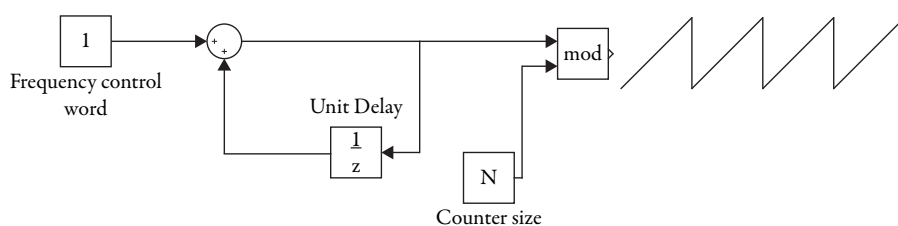

Figure 1: Phase accumulator

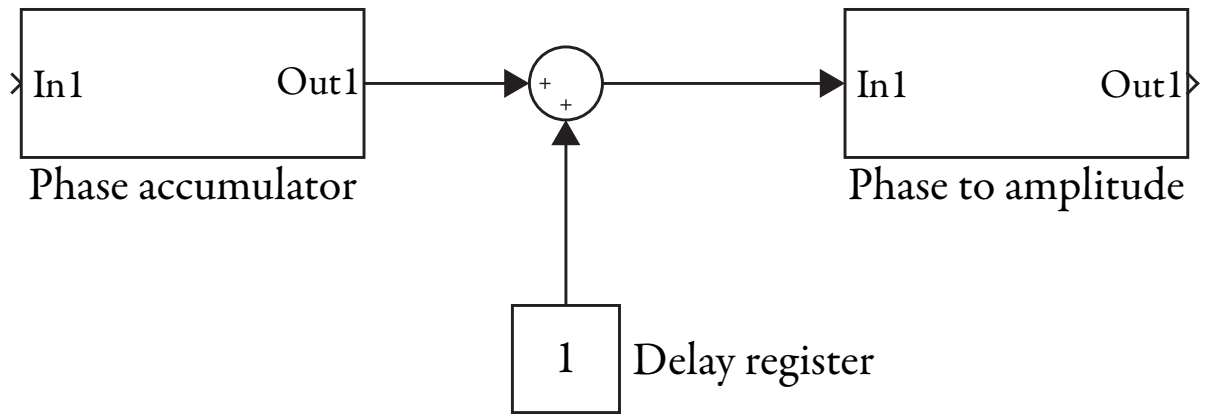

Figure 2: Time delay implementation

The saw tooth is then transformed by a phase-to-amplitude converter to the wanted output waveform. The phase-to-amplitude converter can be implemented with a lookup table where the entries correspond to the output waveform.

The waveform from the phase-to-amplitude converter is then transformed to the analog domain by a digital-to-analog converter. After conversion a filter is applied to remove the high frequency components.

One of the specifications of the system is the variable time delay. In a clocked system a time delay is hard to realize because of the discrete time steps that are taken. To get a delay of 3ps a clock frequency of 333GHz should be used if you want one clock tick to correspond to the smallest delay of the system. This is not realistic for a real system, so another solution has to be found.

A solution to this problem is a phase offset. The DDS creates the saw tooth waveform that corresponds to the phase of the signal. A small offset in this phase corresponds to a small phase offset of the output signal, and thus a small time delay. With this technique the smallest phase offset is determined by the size of the lookup table. The smallest step is given by the following relation:

$$T_{step} = 1/(F_{out} N_{lookup})$$

When the lookup table has  $2^{14}$  entries the delay that can be created at 62.5MHz equals 977fs. See figure 2 for the delay implementation.

The last part of the system is the chirp signal. A chirp is a signal whose frequency changes over time. The DDS system should have at least a linear chirp. The relation for a such a signal equals:

$$y(t) = \sin(2\pi(f_0 t + K/2 t^2 + \phi_0))$$

where K is the chirp rate (e.g. the rate at which the frequency of the signal changes), and  $\phi_0$  the initial phase offset. Note that there are two variables that are integrated over time to acquire the phase of the signal. First of all the frequency is integrated, as in the phase accumulator, and the chirp rate

is integrated twice in time. So, in order to create the chirp signal the chirp rate has to be integrated, and then summed with the frequency to be integrated a second time. See figure 3 for the chirp implementation.

Concluding, a complete digital system meeting the specifications is feasible. The minimal time delay of the system is determined by the number of output bits available, and the frequency resolution is determined by the size of the phase accumulator. The system can be easily scaled to meet the specifications.

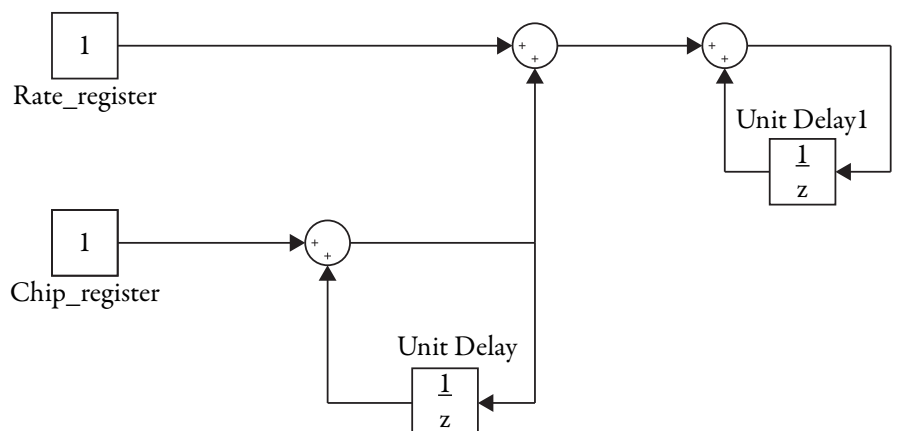
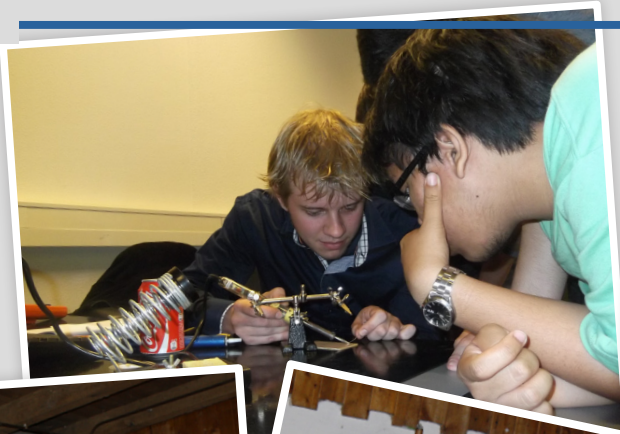
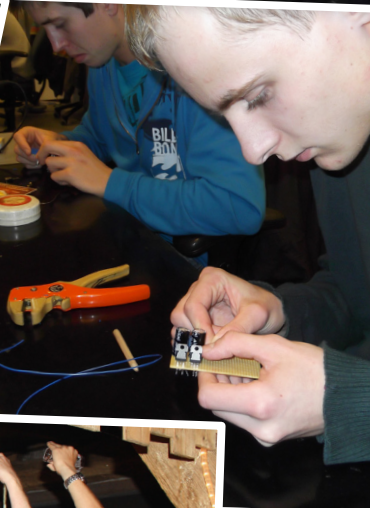

Figure 3: Chirp implementation



Solder co



Introduction camp

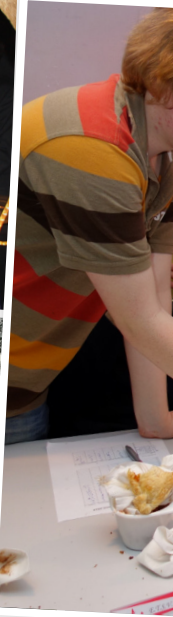



course

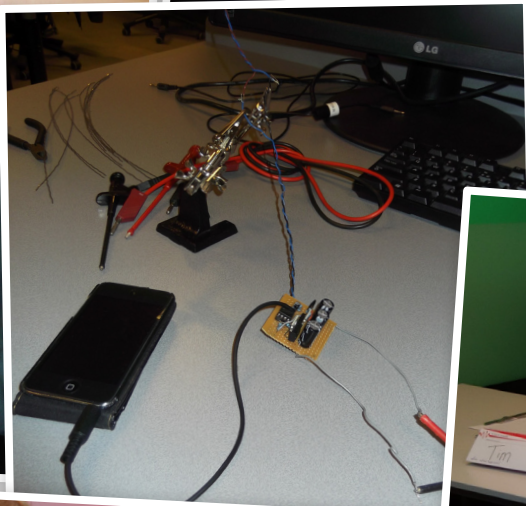

MBEA

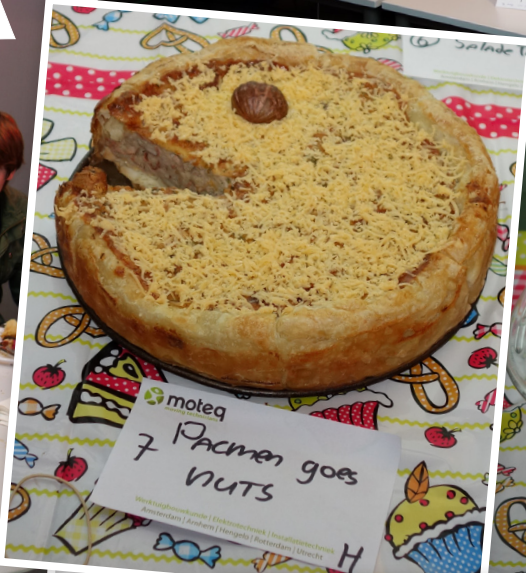

moteq (5) Raspberry Pi



# 3D self-assembled electronics

Authors: Léon A. Woldering, Pieter J. Kamp, and Leon Abelmann

Imagine the following scene, taking place in the year 2046: you enter the production facility for high density memory. No cleanroom suits, no vacuum equipment, but tables with liter-sized vessels that are shaken in repetitive motion. The room is silent, only the humming of the vessels can be heard. The vessels contain a milky liquid. In the liquid thin glass plates are suspended on racks. On the hour an operator robot comes along and removes the racks with plates from the liquid. On these plates gold bond pads can be clearly seen and small cubes of shiny material. You follow the robot. The glass plates are diced, bonded and mounted into tiny SMD packages. You pick one out of the final production line, right after the embossing printer. It reads "3DSA 128 TB". It is a solid state 128 TB memory of only 2 mm size! You hold in your hand the first of a new generation of electronics. Not fabricated by lithography, but grown as a crystal just like the ice flowers on your window in winter. Figure 1 is an artist impression of what such memory devices could look like.

Present day silicon micromachining deals mostly with two-dimensional (2D) systems. For instance, integrated electronic circuitry relies heavily on 2D thin film technologies. As an example, a procedure for etching a simple pattern into silicon is depicted in Figure 2. This particular procedure was used to etch arrays of pores with sub-micrometer diameters and high aspect ratios in silicon [1].

This fabrication procedure relies on a sequence of steps that involve: deposition of a mask material onto a silicon wafer (step I), spin casting a photosensitive layer known as photoresist onto the resulting substrate (step II), structuring this photoresist layer (step III), transferring the structure into the underlying mask material (step IV), and finally etching the defined structure into the silicon material and remove remaining mask- and photoresist material (steps V and

VI). All of these steps are two-dimensional in the sense that they rely on top-down processing of the silicon substrate. An example of the resulting structures is shown in Figure 3. This example demonstrates that the pores are neatly etched, as defined by the 2D pattern in the mask material.

Typical structures in electronic circuitry and magnetic memory are much smaller and much more complicated compared to the array of pores shown in Figure 3. Furthermore, miniaturization leads to increasing density demands and therefore to even smaller dimensions. In the near future, these demands can no longer be fulfilled with existing 2D fabrication technologies, see Figure 4. Consequently, there is a growing need in industry for three-dimensional (3D) silicon micro- and nanostructures [2].

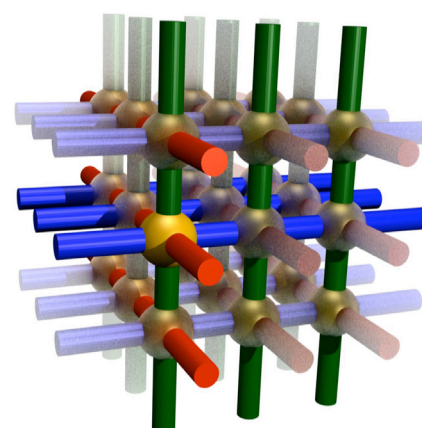

Figure 1: Artist impression of a future 3D crystal-like memory device. In this ball-stick model the spheres are the “bits” on which data is written. These “bits” are addressed using 3 planes of electrodes (here color-coded red, green, and blue). Taken from [2].

## Self-assembly

At TST we are attempting to find novel fabrication methods to obtain 3D silicon nano- and microstructures, which is essential for industry to continue on the path of miniaturization.

We aim to merge silicon micromachining and concepts from self-assembly in order to obtain these 3D silicon micro- and nanostructures. Self-assembly is chosen as the fabrication mechanism because of its proven ability for the formation of 3D systems at almost all length scales, up to several mm's [3].

Self-assembly is multidisciplinary: biologists, chemist, physicists, engineers all have a different view on self-assembly. In order to

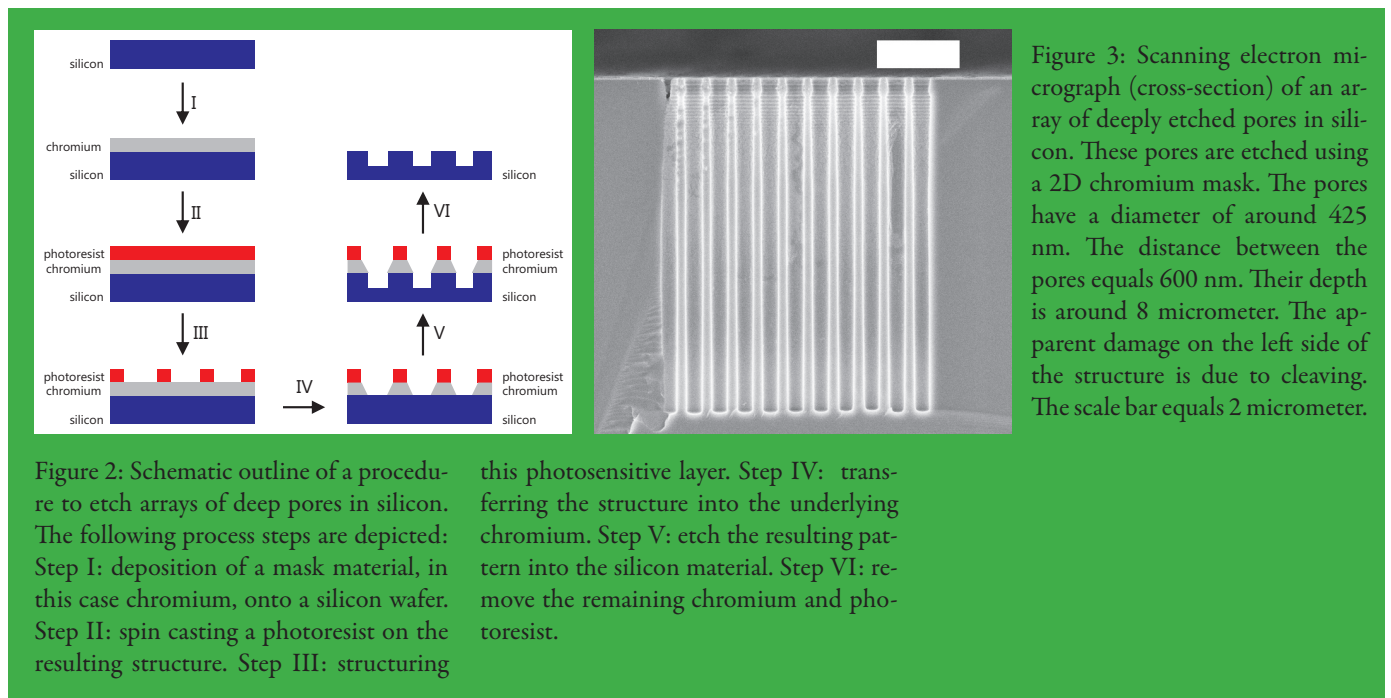

Figure 3: Scanning electron micrograph (cross-section) of an array of deeply etched pores in silicon. These pores are etched using a 2D chromium mask. The pores have a diameter of around 425 nm. The distance between the pores equals 600 nm. Their depth is around 8 micrometer. The apparent damage on the left side of the structure is due to cleaving. The scale bar equals 2 micrometer.

Figure 2: Schematic outline of a procedure to etch arrays of deep pores in silicon. The following process steps are depicted: Step I: deposition of a mask material, in this case chromium, onto a silicon wafer. Step II: spin casting a photoresist on the resulting structure. Step III: structuring

this photosensitive layer. Step IV: transferring the structure into the underlying chromium. Step V: etch the resulting pattern into the silicon material. Step VI: remove the remaining chromium and photoresist.

get some clarity on the subject, it is helpful to provide a framework to define and analyze self-assembly. A definition of self-assembly is given by Pelesko in his book 'Self-assembly: the science of things that put themselves together': "Self-assembly refers to the spontaneous formation of organized structures through a stochastic process that involves pre-existing components, is reversible, and can be controlled by proper design of the components, the environment, and the driving force"[4]. This definition is useful because it helps to choose the parameters with which self-assembly can be controlled, the so-called 'control parameters' of which there are four:

1. structured particles,
2. the environment in which self-assembly takes place,
3. binding forces, and
4. driving forces.

Figure 4: Plot of achieved and predicted area/bit (left) and atoms/bit (right) for 2D memory devices as a function of time in years. As the capacity of memory devices increases, the area used per bit is reduced. From the trend line (dotted) it is apparent that after around 2020, bits will be defined by a few atoms only. Further improvements in density will be impeded by this limit.

These parameters will be discussed below: The structured particles are the components of the system which self-assemble into the desired structure. Self-assembly can be guided by engineering the particles such that formation of the desired structures is statistically favored. One example of our research is that we are investigating the self-assembly of sub-micrometer silicon particles, see for example Figure 5 A. This Figure schematically depicts truncated tetrahedra. These particles will be made using conventional (2D) silicon micromachining fabrication processes and have typical sizes of around 350 nanometer. Subsequently, we aim to self-assemble these particles into a structure which resembles the way carbon atoms are

oriented in a diamond crystal, see Figure 5 B. This is achieved when the particles connect to each other at the faces depicted in blue and with the right orientation. The environment provides boundary conditions on the movement of the self-assembling particles. The boundary conditions can be provided by the physical edge of the system in which self-assembly takes place, the medium in which the particles are suspended, and by external forces acting on the system such as gravity. The binding forces are the forces which are responsible for the attraction between the structured particles. Examples of binding forces are: chemical, electrostatic, magnetic and gravitational (in the case of stellar

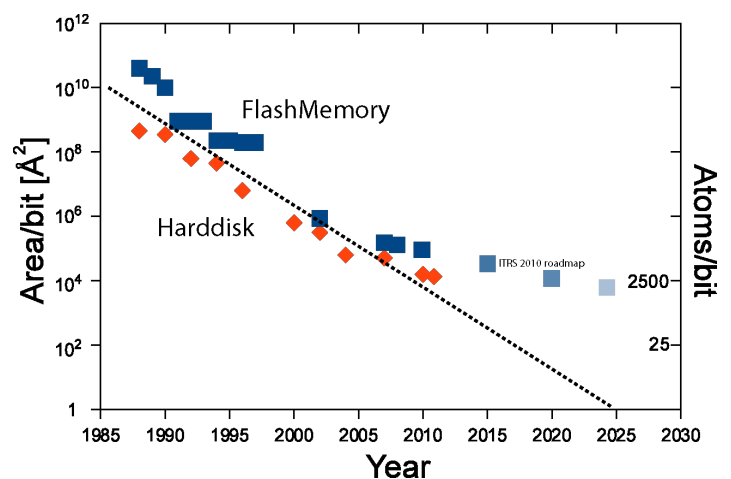

*Figure 5 A: schematic illustration of two silicon truncated tetrahedra. When self-assembly is successful, these particles will form a crystal as shown in B. The target dimension of these particles is around 350 nm. The faces that are depicted in blue are the faces at which inter-particle binding should occur. B: schematic illustration of part of a crystal that is formed when truncated tetrahedra self-assemble in the intended fashion. The position of the constituent particles resembles the way carbon atoms are arranged in a diamond crystal. At the bottom the substrate is shown on which self-assembly experiments will be attempted.*

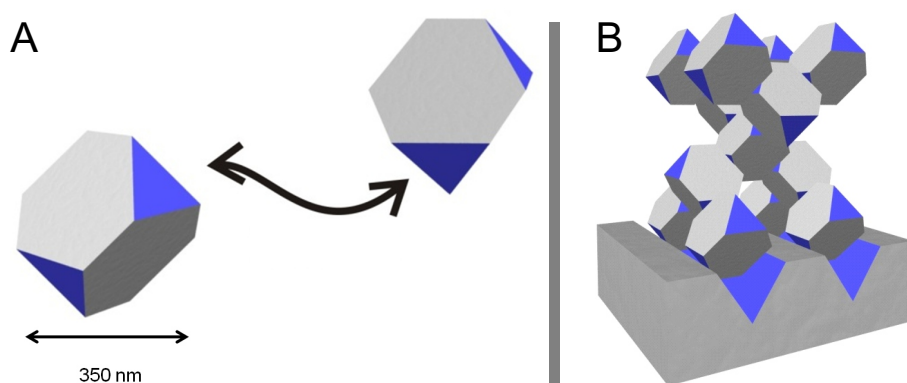

systems). In the case of our truncated tetrahedra, the binding forces will be generated between the faces that are depicted in blue in Figure 5.

The driving forces in self-assembly ‘drive’ the process towards local energy minimization. Driving forces agitate the system, providing energy and mobility to the particles. These driving forces are preferably stochastic. Examples of driving forces are: physical oscillation of the system, thermal noise, and a fluctuating electromagnetic field. We foresee that in the case of our experiment the driving forces will be due to thermal noise or generated by ultrasound.

## Finding the optimal self-assembly conditions

Self-assembly generally can be divided into static and dynamic self-assembly. In dynamic self-assembly processes ordered states only exist when the system is dissipating energy. For example: a living cell only works and lives when it is dissipating energy. Here we consider static self-assembly.

Static self-assembly processes drive towards a local energy minimum: particles tend to find the lowest state of magnetic energy locally available. If the energy landscape is engineered in such a way that the desired assembled state is in a lower energy than other configurations, this state is preferred.

One of the challenges in this research is to find the optimal balance between the binding forces and the (distorting) driving forces at which the desired configuration can be obtained with a high yield. We look at this challenge in terms of the respective binding- and distorting energies in the system. Making truncated tetrahedral particles in the cleanroom and functionalizing them such that they exhibit inter-particle binding forces is time consuming and expensive. Furthermore, many attempts would be needed to determine the optimal ratio between the binding- and distorting energies. Therefore we have decided to attempt to experimentally determine this optimal balance using macro-sized self-assembly experiments and, once sufficient knowledge has been obtained, extrapolate the results to sub-micrometer scales<sup>1</sup>. In the remainder of

*Figure 6 A: schematic illustration of the used tetrapods. Embedded in each of the pods is a disk-shaped Neodymium magnet. The height of these pods is around 2 cm. B: photograph of 3D printed tetrapods. The central part and the caps were glued together after the magnets are placed.*

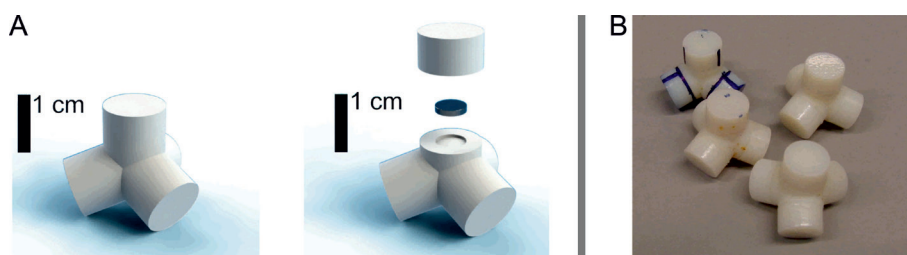

<sup>1</sup> A discussion on why the energy ratio derived from macro-scale experiments can be applied for self-assembly using sub-micrometer particles is beyond the scope of this article. However, a few words can be added. Our working hypothesis is that the investigated self-assembly systems can be described using Boltzmann distributions. In these distributions, the probability to find particles in a certain state depends on the ratio of binding- and distorting energies, and not on the magnitude of these respective energies. Therefore, these probabilities are independent of scale. Many of the experiments that we are currently performing are intended to test the hypothesis that Boltzmann distributions describe our system.

this article, the setup that we use for these experiments will be discussed, as well as an experimental example.

## A macro-scale experiment

Our macro-sized experiment will be described in more detail using the four control parameters:

1) We have selected 3D printed tetrapods as our structured particles, see Figure 6. These particles were printed at the Control Engineering group of the University of Twente using an opaque white plastic. Embedded in each of the pods are disk-shaped N35 quality Neodymium magnets. Two of these point outwards with their North-pole, the other two have their North-pole pointing inwards. This specific magnet configuration is required for assembly into the desired structure. The height of these tetrapods is around 2 centimeters.

2) The setup, or the environment, that is used for our experiments is shown in Figure 7. It consists of an outer tube and an inner tube which are filled with water. A diffuser generates a flow of air bubbles at the bottom of the inner tube. For self-assembly, particles are entered into the confinement of the inner tube, which is then closed by filters. Water is chosen as the medium because of the small relative difference in density with regards to the particles and because it is easy to work with. The particles are hovering in the setup due to a flow of water from the

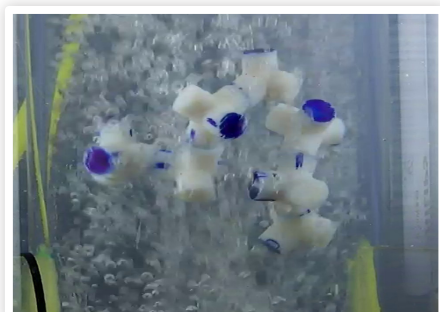

Figure 8: photograph of an experiment in which many tetrapods were entered into the system. In this case the tetrapods organize into 2 separate chains. The particles are being agitated by the flow of air bubbles in the surrounding medium.

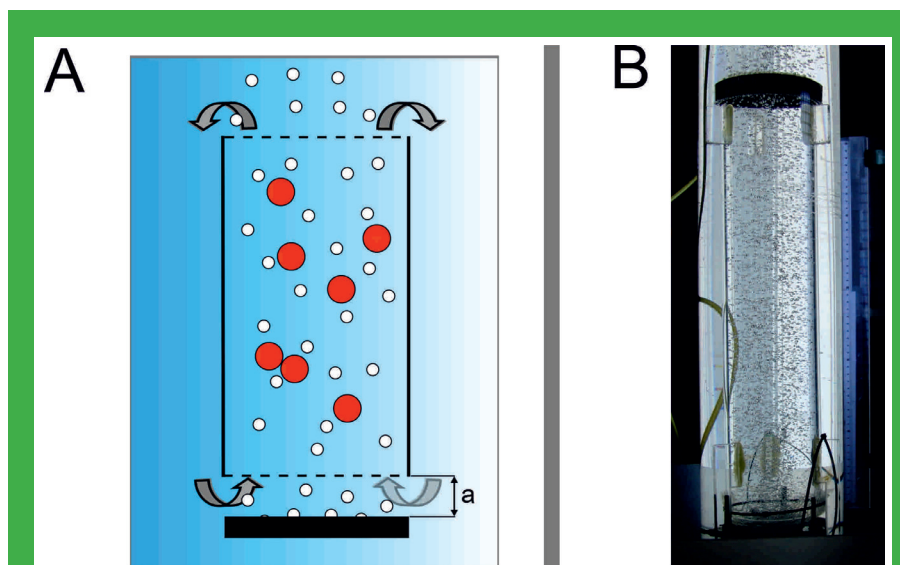

Figure 7 A: schematic view of the setup used to perform self-assembly. Air bubbles (white circles) are pumped through the diffuser that is placed under the inner tube to agitate the particles (red circles). The flow of water (the grey arrows) needed to let the particles hover is generated by the upward flow of air bubbles. We have proven that the distance  $a$  between the diffuser and the inner tube controls the flow of water into the inner tube. The

optimal value for our experiments was  $a = 1.5$  cm. B: photograph of the setup that was used to perform self-assembly. The outer tube and inner tube are visible. Filters are placed at the bottom and top of the inner tube. Part of the diffuser providing the flow of air is shown at the bottom of the setup. The setup is illuminated from the back. A consistent flow of air bubbles is visible.

bottom to the top. This water flow is generated by the flow of air in the system.

3) The inter-particle binding force is generated by the permanent magnets which are embedded in the tetrapods. Magnets with different sizes were used in order to vary

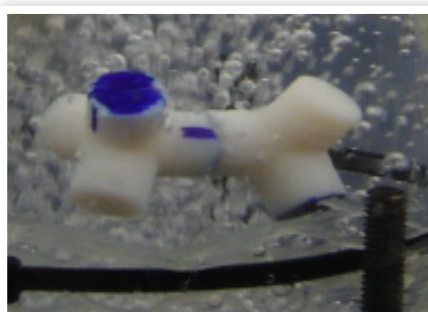

Figure 9: photograph of a dimer formed by 2 tetrapods. The particles are color-coded in order to distinguish the pods that contain magnets with the North pole facing outward from pods where it is facing inwards.

the binding force. One of the advantages of using magnets is that their behavior is well understood and can be analyzed in a straightforward fashion.

4) The driving force, or distorting energy, in this system is caused by the flow of air bubbles, see Figure 8. The air bubbles, whilst travelling upwards in the inner-tube of the setup, cause the particles to move around randomly. In this fashion the distorting energy needed for self-assembly is generated. By increasing the flow rate, more distorting energy is added to the system. Therefore the air flow rate is a very useful parameter to tune the ratio of binding- and distorting energy.

To verify that the distorting energy is indeed dependent on the air flow rate we performed the following experiment. Two tetrapods embedded with magnets were added into the system. These two particles have the potential to form a dimer, see Figure 9. However, at low air flow rates (low distorting energies) we expect dimers to

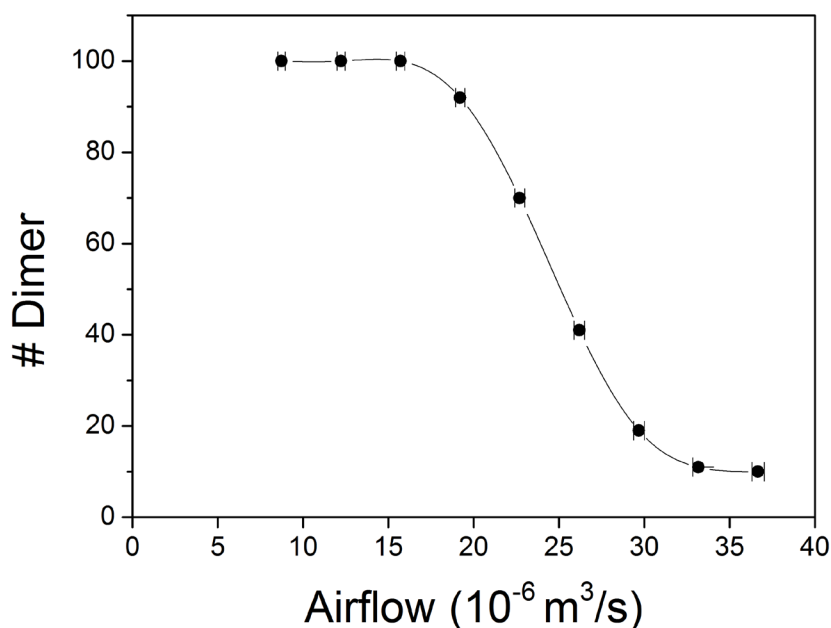

Figure 10: measured occurrence of dimers when two tetrapods interact at different air flow rates. At low flow rates dimer occurrence is nearly 100%. At high flow rates the frequency with which a dimer is observed decreases rapidly. The line is a guide to the eye.

be formed more easily compared to experiments at higher flow rates. At higher air flow rates, the particles are in an environment with more distorting energy and the inter-particle bond between the tetrapods is more easily broken. Breaking this bond causes the dimer to fall apart.

We observed the occurrence of dimers at 100 instances for different air flow rates, see Figure 10. It is apparent that for low flow rates the occurrence of dimers in the setup is almost 100%. When the air flow rate is increased, the amount of observed dimers significantly decreases. At high air flow rates, almost no dimers are formed. From this experiment we can conclude that this setup is a very useful tool to study the opti-

mal ratio of binding and distorting energies. Currently, we are continuing to investigate under which conditions three-dimensional self-assembly of the tetrapods into the desired structures occurs. The results of this macro-scale research may offer a deeper understanding of the fundamentals of self-assembly and will be extrapolated to the sub-micrometer scale. At the TST group we have many interesting self-assembly assignments available (B.Sc. and M.Sc.). These assignments are related to the subject described in this article and also to many other projects. Please feel free to contact the authors if you want to know more. More information is also available at [tst.ewi.utwente.nl](http://tst.ewi.utwente.nl).

## References

- [1] L.A. Woldering, R.W. Tjerkstra, H.V. Jansen, I.D. Setija, and W.L. Vos, "Periodic arrays of deep nanopores made in silicon with reactive ion etching and deep UV lithography", *Nanotechnology* 19, 145304 (2008)
- [2] L.A. Abelmann, N.R. Tas, J.W. Berenschot, and M.C. Elwenspoek, "Self-assembled three-dimensional non-volatile memories", *Micromachines* 1, 1-18 (2010)
- [3] G.M. Whitesides and B. Grzybowski, "Self-assembly at all scales", *Science* 295, 2418 (2002)
- [4] J.A. Pelesko, *Self-assembly: the science of things that put themselves together*, Chapman & Hall/CRC, Boca Raton (2007)

# SEED Studio

Author: Rowan de Vries

The study tour Lián Xi was in China for three weeks and visited many companies. One of these companies uniquely distinguished itself in nearly every way possible; practically all employees are younger than 30, their method of gaining new products is special and more generally their world view and mission are the product of free thought.

Our bus actually drove right past the building where the studio is situated. It is uphill from the road and, like all Chinese companies, behind a guarded barrier. An ugly compound with a few flats built from communist concrete. The entrance is a big steel door leading to a staircase and a huge lift. By huge I mean more than 20 people will fit in the opening. After reaching the appropriate floor the first thing that catches the eye is the metal sliding door which is opened as well as the nicely decorated glass door behind it containing the Seeed logo. Inside, everything is decorated; the floor and the walls as well and everything was done by the employees themselves!

---

“By huge I mean more than 20 people will fit in the opening”

---

What is so special about this city we are in?

Shenzhen is a city in the south-east of China directly above Hong Honk. It was the first special economic zone in China and that has resulted in major investments from western companies. More precisely for the past twenty years Shenzhen has been one of the most concentrated places for electronics components and electronic products manufacturing. This can be seen on the streets by the large amount of electronics markets with products build in the city, they sell li-

terally everything from resistors and capacitors up to fully finished consumer products. When the founders of Seeed Studio started making products they used to go to these markets to get the materials required.

What can Seeed contribute to my project?

By being in close contact with manufactures Seeed Studio can easily find a place to produce your product and has a community to sell to. They can do this fast and in low volume, making this an ideal platform to test and sell your prototypes. It is also possible for designers to sell their designs and let Seeed Studio develop the technical implementation. This is shown in short in Figure 1.

How do you make money from this?

Well there is revenue from producing and selling the product via the website, but we are also allowed to sell the products in Shenzhen and keep that profit ourselves. However this last category only amounts to about one third of the total volume of the top products produced.

Do you also perform your own research?

Yes, we design our own proto-shields and implement the software for designers who want us do so.



Figure 1: The SEED circle

When the study tour visited the R&D department we saw a room that looked a lot like the ‘W-zaal’ at our University during the ‘mechatronica project’ except that they were all using Seeeduino’s (similar to Arduino’s).

Can students get an internship here?

There hasn’t been anyone from the Netherlands yet but there has been a student from Europe and one from the USA, so you are more than welcome. Naturally we would have to look at each case separately to see if and what can be arranged.

# Spam filtering at Scintilla

*Author: Erwin Bronkhorst*

With the growth of the internet, the number of spam messages that is sent every day increases exponentially. Almost everybody who uses e-mail uses some kind of spam filtering to remove the annoyances of these messages. However, spam is not only negative to the owner of an e-mail address, but it also has some negative consequences for system administrators nowadays. In this article, an impression of the problems that spam causes is given, and it will be described how the Scintilla Operator Team (SOT) deals with spam.

First of all, it is important to know how e-mail works. When somebody sends an e-mail to `sot@scintilla.utwente.nl`, the e-mail is presented to the configured SMTP-server of the sender, mostly the one of the internet service provider (ISP) of the webmail provider. Let's take an example, where somebody sends an e-mail from within Gmail. In this case, the SMTP-server of Google is used. Google knows that a message for an `@scintilla.utwente.nl` address should not be delivered at its own location and tries to forward the message. The SMTP-server of Google now looks for the MX-records of the domain 'scintilla.utwente.nl'. MX-records are a type of DNS-records and you can do a lookup yourself with the 'host'-command on Linux, or on certain websites [1]. For the domain `scintilla.utwente.nl`, there are two MX-records present. These records are shown in Figure 1.

```
user@host$ host -t MX scintilla.utwente.nl
scintilla.utwente.nl mail is handled by 100 mx.utwente.nl.
scintilla.utwente.nl mail is handled by 10 smtp.scintilla.utwente.nl.
```

Figure 1: On a Linux computer, you can look up the MX-records for a domain or hostname with the 'host' command. The hostname `scintilla.utwente.nl` has two MX-records.

For MX-records, a hostname and a priority is present in the record. In the above example, there are two MX-records present: `mx.utwente.nl` with priority 100 and `smtp.scintilla.utwente.nl` with priority 10. A low number for the priority means a higher priority, so Google will first try to deliver the message to `smtp.scintilla.utwente.nl`. In most e-mail environments, the MX-record with the lowest priority value will respond and the message is delivered to the target mailserver. However, Twente University blocks port 25 (which is used for SMTP) on (almost) all hosts at UTnet, including on the mail server of Scintilla. The result is a timeout. Now, the SMTP-server of Google will continue with the next MX-record, in this case `mx.utwente.nl`. This is the mail server of Twente University and it accepts the message.



This mail server knows that the message should not be delivered on that local mail server, in the same way the mail server of Google knew it should send the message to another location. The mail server of the university again checks for the MX-records and sees `smtp.scintilla.utwente.nl` as primary mail server. Because the mail server of the university is on the same network, port 25 is not blocked and the message is delivered to the mail server of Scintilla. This mail server knows that e-mail for `sot@scintilla.utwente.nl` belongs to himself and delivers the message locally, instead of sending it to another SMTP-server. The whole e-mail flow is shown in Figure 2.

## SpamAssassin

With this local delivery, the interesting part for spam filtering is started. Each message is scanned by a program called 'SpamAssassin' [2]. This program uses different techniques to check if an e-mail message is spam or not ('ham'). The program uses a rating system, starting at value 0. For some properties of the e-mail, mostly present in spam-messages, it gives positive points and



for some other properties, mostly present in ham-messages, negative points. When all configured techniques are used, a final score is given to the message and placed in the e-mail headers. The message is now processed the normal way. Most normal e-mail messages get a negative score of around -2.5 points. Newsletters get a higher score, often around 2.0 or 3.0 positive points. At a score starting from 5.0, it is most likely a spam-message and for messages that get a score of 10.0 or higher, the spammer probably does not know how to send a legitimate-looking message. To make filtering for users more easy, spam-messages get a [SPAM]-tag in the subject and are placed server-side in the spam-box already.

In the next part, a few components that are used to give a score to the message are presented. Besides these components, there are a lot more available. You can find them at the website of SpamAssassin [3].

## DNS blacklist

Most spam messages are sent by a computer that is infected with malware, or via a SMTP-server that accepts messages from the whole world. Therefore, a large part of the spam message originates from a relatively small amount of hosts. Some organizations, for example Spamhaus [4], analyze spam-messages and look in the e-mail headers through which hosts the message was sent. If one host (workstation or SMTP-server) is present in a lot of spam messages, it is probably infected and the chance that another message from that host is spam, is higher. Therefore, the IP-address of that host is placed on a blacklist.

SpamAssassin looks for every message that it receives in the blacklist and checks if the originating host is present on this blacklist. If the host is present, this filter adds approximately 3.0 points to the spam score. Unlike many other checks, this one never adds a negative score to the message.

## Subject blacklist

A lot of spam messages are sent multiple times, with the same or a little modified subject. Most of these subjects are not likely to be used in legitimate e-mail messages, for example "You can be anyone you want with University Degree". Therefore, the mail ser-

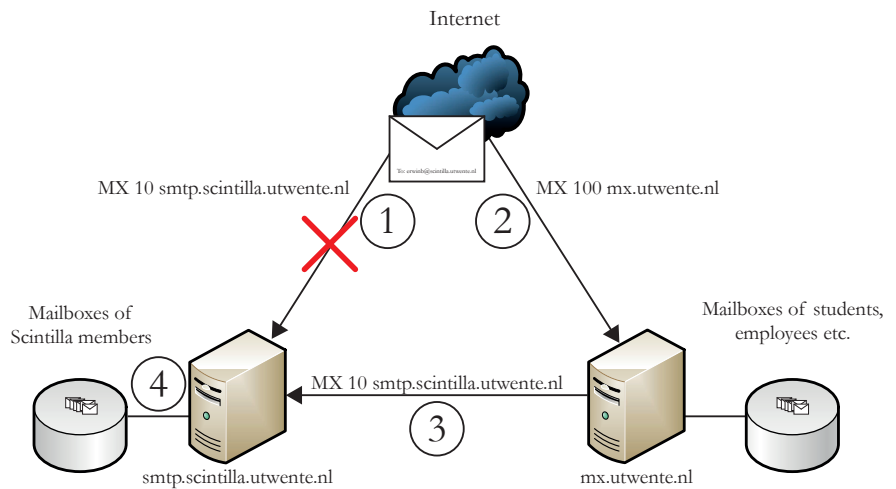

Figure 2: This image shows a schematic view of a message that is send to an e-mail address that ends with @scintilla.utwente.nl. The left mail server represents the mail server of Scintilla, the right one is the mail server of the University of Twente. The message can not be delivered directly to Scintilla, and is therefore delivered via the mail server of the UT.

ver at Scintilla has a blacklist of subjects that are used in common spam messages. If the subject of the e-mail message is present in this blacklist, it adds 3.0 points to the spam score.

This components also uses a white list for

---

“Most spam messages  
are sent by a computer  
that is infected with  
malware.”

---

subjects that are used mostly in ham messages. However, most ham is manually written with a custom subject line. Therefore, this check is not often used. At Scintilla, it is used with a wildcard for some automatic e-mail messages from, for example, the ticket system TRAC. When the subject matches a subject from the whitelist, a negative score of -3.0 is added to the spam score of the message.

## Autowhitelist

The autowhitelist (or short AWL) check keeps track of spam scores related to the e-mail address of the sender and the IP-address of the sender. It averages the spam scores from the past for that sender and for each new message, it gives a score that

brings the new message more to the average value. For example, if erwinb@scintilla.utwente.nl on average sends messages with a spam score of -2.5 and a message with score 5.0 is received, it is most likely that Erwin sent a legitimate e-mail with some strange words in it. The AWL-component will add a negative score to this message, to make the final score closer to the average.

This also works in the other direction: if a spammer sends messages with an average score of 7.0, but somehow it succeeds in sending in e-mail with score 1.0, the AWL-component will give extra points, based on the history.

Due to the fact that the average is based on the total history of a sender, it is self-learning and when somebody sends more and more spam messages, it will give him a higher score over time.

## Bayes

The Bayes scanner is the most complex component of the ones that are described here. The Bayes scanner uses a Bayesian algorithm to decide which message is spam and which one is ham. Before the scanner knows this, it is required to feed the scanner some messages, telling it whether it is spam or not. The scanner analyses the messages and places several properties (used words, the order of words in sentences and other factors) of the message in a database. When enough messages are scanned, the scanner is

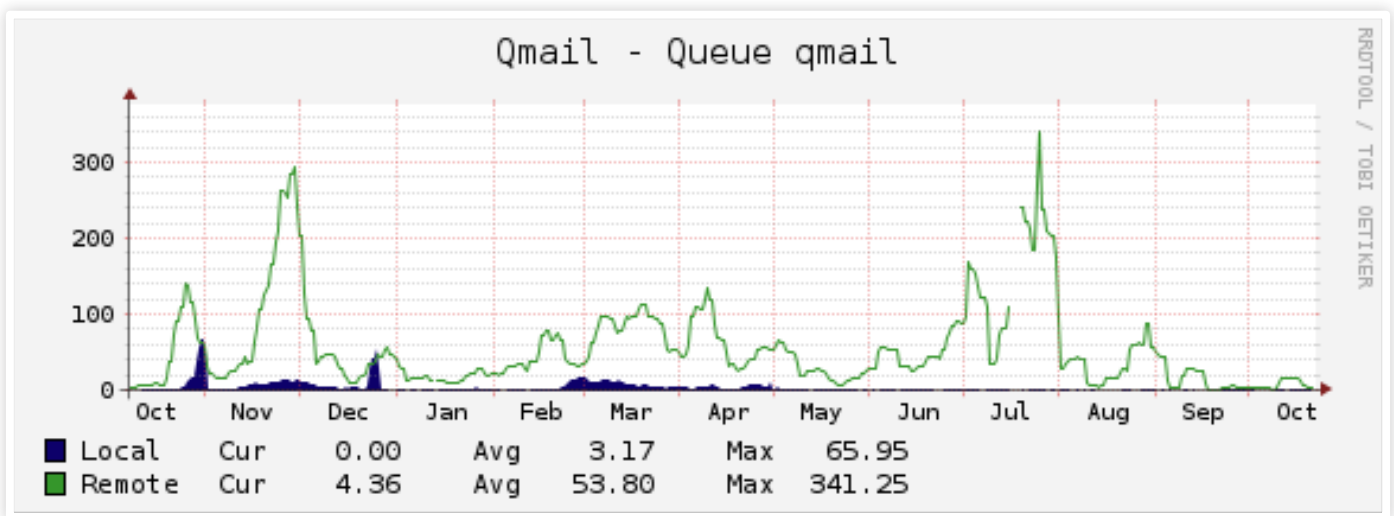

Figure 3: In this picture, the size of the remote mail queue at Scintilla is shown over the last year. The queue is mostly filled with delivery notifications to non-existing e-mail addresses. The ongoing spam runs are clearly visible in the peaks of the remote queue. At the end of July, SOT retrained their filters, resulting in a permanent lower queue.

capable of identifying messages to be spam or not. Each message gets a probability to be spam. A probability of 50% gives 0.0 points, a score of 99%-100% rates a message with 3.5 extra points, a probability of 0%-1% results in -3.5 extra points for the final spam score of the message.

The scanner uses properties of spam and ham and therefore, it is important to feed the scanner with both types of messages. Furthermore, it is important to keep the scanner learning, because the Bayesian properties of e-mail messages change over time. Luckily, the scanner has an auto-learn-function, which learns messages with a final score above a certain threshold as spam, and messages below another threshold as ham.

### Contents

The most basic and probably the oldest way is scanning, is looking to the presence of certain words in the message. These scanners are the main reason that in most spam-messages, Viagra is written as V1@gr@ and nice synonyms for the human genitalia are used. This component also looks for high sums of money (\$5 MILLION DOLLARS) in the message and messages get a higher spam-score if they are started with 'Dear friend'.

## Valid recipients

With all these components of SpamAssassin, the harassment for users is reduced to a minimum. However, for the system administration, there still is a problem.

A lot of spammers use fake addresses to send e-mail messages from and, unfortunately, also send e-mail messages to fake addresses. Usually, when you send an e-mail mes-

---

“With all these components of SpamAssassin, the harassment for users is reduced to a minimum.”

---

sage to a non-existing e-mail address, you receive a Delivery Notification or Bounce, telling you that the message could not be delivered. This also happens to the senders of spam-messages, who sent the message to a non-existing address, resulting in more e-mail traffic. The most problematic case is when the address of sender is unreachable, because there is no (active) MX-record. In this case, the mail server of Scintilla will keep the message in the outgoing queue and tries to send the message later in a few hours. If the message could not be delivered

within approximately two weeks, the message is discarded. You can see the effect of this in Figure 3.

Especially this high mail queue is a problem, because at very high values, it can slow down the delivery of legitimate e-mail messages. Therefore, SOT has made a tool that discards a message if it is sent to a non-existing e-mail address and has a high chance of being spam. With this tool, the queue of the outgoing messages decreased significantly.

Due to the fact that this tool did such a good job, SOT decided to use the tool also to immediately remove messages that are really likely to be spam (a score above 15.0). This makes it easier for users to check their spam folder for legitimate message, because the amount of spam is reduced.

It is a bad practice to remove all messages that are sent to a non-existing e-mail message, because you can imagine that someone makes a typo in their To-field. These people are happy to hear that they made a mistake and that they have to re-send their message.

## Conclusion

SOT is constantly trying to make the spam filter better and better. This is, however, impossible without the information of e-mail messages that are sent through Scintilla. You can also help to make the spam filtering

better, especially when you find false detections: a spam message that is not tagged as spam, or a legitimate message that is tagged as spam. Please, contact SOT in these cases, to make sure the filters learn from their mistakes.

If you are interested in the work SpamAssassin has done for a certain message, you can look in the headers of the message. Google had placed a manual to look up the headers of a message in several e-mail clients [5]. The details of the SpamAssassin-scan are shown in the header with the name “X-Scintilla-Status”. Here, you can see why a message is tagged as spam, or why not. An example is shown in Figure 4.

In the beginning of this article, you could read that all e-mail messages that are delivered to Scintilla, are delivered via the mail server of Twente University. That mail server also uses SpamAssassin to scan the e-mail messages. The results of this scans, are also shown in the headers of the message. It is nice to compare the results of the Scintilla spam scanner to the one of the university. You should see that the scanner of Scintilla

performs better in most of the cases.

If you have any questions after reading this article, you can contact SOT via the e-mail address [sot@scintilla.utwente.nl](mailto:sot@scintilla.utwente.nl). If you like managing an e-mail server, or other aspects of system administration, you can also contact us. The Scintilla Operator Team is always looking for people that enjoy system administration that goes beyond the administration of your own home server.

## References:

- [1] <http://mxtoolbox.com/>
- [2] <https://spamassassin.apache.org/>
- [3] [https://spamassassin.apache.org/tests\\_3\\_2\\_x.html](https://spamassassin.apache.org/tests_3_2_x.html)
- [4] <http://www.spamhaus.org/>
- [5] <https://support.google.com/mail/bin/answer.py?hl=en&answer=22454>

## Spam factoids

Spam is a collective term for all kinds of unwanted e-mail messages. Not only the advertisement messages about male enhancers or big casino wins are called spam, but also phishing messages from evil people which pretend to be your bank, can be indicated as spam.

The first spam message was sent in May of 1978. It was an invitation to come and see a new computer of the company ‘DEC’. The message was sent to 393 users of ARPANET, the progenitor of the internet as we know it. One big annoyance of the message was that all recipients were placed in the TO: header. The list of addresses was longer than the size of the whole e-mail header, resulting in an overflow of addresses in the mail body. To make the annoyance even bigger: the whole message was written in upper case. The message resulted in a lot of complaints.

We owe the name ‘spam’ to Monty Python, who made a sketch about unsolicited advertising on tv. Spam is canned meat which can be eaten. In the sketch, people in a lunch room get spam served, even if they did not order it. Furthermore, other people are singing an annoying song about spam, making normal conversation very difficult. The relation with e-mail spam is clear: without good spam filters, you can hardly find the legitimate messages due to the spam.

Spam is mostly sent by botnets, build with thousands of infected computers. Altogether, these computers can send out a large amount of e-mail messages. Also open SMTP relays (mailservers that accept any message from any hosts) and vulnerabilities in website software like Joomla can be used to send out spam messages.

It is hard to imagine a world without spam, so the best way to deal with it now is to use good spam filtering, resulting in less spam messages in your primary inbox. Furthermore, keep your computer clean from viruses and malware, to prevent you becoming part of a botnet and send spam messages yourself.

```
X-Spam-Contact: sot[at]scintilla[dot]utwente[dot]nl
X-Scintilla-Score: score=14.2
X-Scintilla-Flag: YES
X-Scintilla-Checker-Version: SpamAssassin 3.2.5 (2008-06-10) on
  qmail-utelscin.scintilla.utwente.nl
X-Scintilla-Level: @@@@
X-Scintilla-Status: autolearn=no, summary=
  3.0 RCVD_IN_XBL          RBL: Received via a relay in Spamhaus XBL
  [abc.de.fgh.ij listed in xbl.spamhaus.org]
  3.5 BAYES_99            BODY: Bayesian spam probability is 99 to 100%
  [score: 0.9998]
  0.6 US_DOLLARS_3       BODY: Mentions millions of $ ($NN,NNN,NNN.NN)
  0.0 HTML_MESSAGE       BODY: HTML included in message
  1.5 MIME_HTML_ONLY     BODY: Message only has text/html MIME parts
  2.2 DCC_CHECK           Listed in DCC (http://rhyolite.com/anti-spam/dcc/)
  2.0 URIBL_BLACK        Contains an URL listed in the URIBL blacklist
  [URIs: mycastaner.com]
  0.1 HTML_MIME_NO_HTML_TAG HTML-only message, but there is no HTML tag
  1.2 ADVANCE_FEE_2      Appears to be advance fee fraud (Nigerian 419)
  0.1 RDNS_NONE          Delivered to trusted network by a host with no rDNS
X-Scintilla-Problem-Solution: In case of wrong recognition, please contact.
```

Figure 4: The mail headers of a obvious spam message. Under X-Scintilla-Status, the scores of SpamAssassin are shown. The first column (3.0) shows the score per component, the second column (RCVD\_IN\_XBL) shows the name of the check and the last column contains the motivation for the score.

# SKIC camp

What do you think about when I mention the highland games, the Cantus Scintillae and De Lutte in one sentence? Most of you must be thinking about the Scintilla Kick-In Camp, which takes place every year during the kick-in. But these are not the only things that could be associated with our Faculty Kick-In. Do you want to know what also happened in this year's faculty Kick-In? Let's find out...

## A gentle bike-ride

As we did almost every year, we went to our idyllic campsite located in De Lutte, owned by the world-famous 'Boer Frans', by bike. The freshmen were sent away in their do-groups one by one, along with some directions. Some groups understood them better than others, but in the end, as the journey to the camp location went prosperous, everyone was glad to attend the trip. Unless you run a flat tire after five minutes of cycling, of course.

When all the freshmen arrived at our camp location, they were welcomed by the scent of freshly delivered food, and were finally able to fill their empty bellies with it. After dinner there was some time to relax. Time which could be filled by having a chat with your study mates, playing a game of boules, drinking a couple of beers or whatever you wanted, knowing that it would become a long night.



*Author: Daniel van den Berg*



## Midnight madness

Around ten o'clock in the evening, the first expedition group was dropped. Since most Electrical Engineering students are of course accompanied with their state of the art smartphones, we thought it was way more fun to just give them a coordinate and let them visit that location. Not knowing that they would be walking away from the primary objective: going to the campsite. The place corresponding to the coordinates would be the official Scintillian Refreshing Point (SRP). We were happy to supply every group at our SRP with new courage and energy, with the thought that they had to walk all the way back again, and even further. In the late hours of that day, back again at the camp location, we were able to welcome all the groups, who were covered in blood, sweat and tears but who were also relieved that they finally got to their new temporary home.

The Kick-In is not the time during which you get the most sleep of your life. On Tuesday the freshmen faced an unwelcome surprise when they were woken up roughly by private Kooyman after a mere three hours of sleep. After a short but rough morning exercise, the freshmen had a nice breakfast. As expected, there was a bit of a drowsy ambience. I still wonder why...

## Gettin' dirty

Now it was time to show the freshmen the reason why they had to bring clothes that were allowed to become dirty. The highland games were about the start. Ingredients: flour, yoghurt, syrup and loads of eggs. This could be the beginning of a pie recipe (maybe a hint for next year?), but in Scintillian thoughts this could only be the recipe for the highland games! The goal of the games is to get as many points as possible by completing different games using the earlier enumerated ingredients. At least, that is what they were told. The 20 person audience were just waiting for the long-expected food fight to begin. After a short while, the battle broke lose. Chaos only became bigger when the president and treasurer of Scintilla spiced things a bit up by running onto the battlefield with some eggs and flour. Luckily there were no casualties after the highland games came to an end.

After a quick clean-up to get rid of the flour and large chunks of egg, the new students had become quite hungry, so they were glad when they could finally enjoy their lunches. With their bellies stuffed, the group went on a journey. The destination was the swimming pool in a nearby village called Dene-kamp. Like any other year, this is the perfect opportunity not only to refresh a bit from the little amount of sleep, but especially to wash away the dirt. When everyone was as fit as a fiddle, we returned to our luxurious



camp location, where the barbecue was already awaiting to be lit. While the candidate-board was proving how good they are at turning meat, some new guests were welcomed at the campsite. They did not come there just for the barbecue, but for the mysterious event that would take place later that evening...

---

“Luckily there were  
no casualties after the  
highland games came  
to an end.”

---

That event would be the Cantus Scintillae, a festivity with lots of singing, bragging, and drinking Grolsch Premium Pilsener, an activity which is already deep rooted within the Scintillian tradition. That evening would be one of many ad fundums, poetic stories and false singing: all in all, the best ingredients needed for an unforgettable night.

When the Cantus came to an end around 1.00 AM, there was the possibility to have another drink and to talk both the Cantus and the last few days over. Some people were exhausted, either by insomnia or beer, and decided to go to bed, while others just went on till the early hours.



## The hangover

During such a camp with little sleep, you could clearly observe a drop in energy each day. Wednesday the 29th of August was the last day, and despite the lack of energy, there still had to be cleaned up. Even though there were several people who couldn't keep their eyes open, the cleaning job went very well. It was time for the freshmen to return to the beautiful city of Enschede, where the last two days of the Kick-In would take place. This year too, the Kick-In camp has been a success. Let's hope next year it will be even better!

I would like to thank everyone who helped making the camp to a success, including De Borrel, Scintilla's 82nd and 83rd board, the Cencores Cantus Scintillae, de Oude Lullen and of course all of the participating freshmen!



# Study project Lián Xì

*Author: Freddy Gunneweg  
Photos: Freddy Gunneweg*

As many of you will have noticed, the last couple of months have seen a lot of extra activity in the Scintilla room, followed by a period of relative silence during the first six weeks of this college year. All of this is a result of Scintilla's latest study project, called Lián Xì. Following the success of last year's trip to the U.S., we decided to organize our next trip in the same manner, which meant that every participant is actively involved in the organization of the trip. Some of us were charged with obtaining sufficient funding, while others managed the money, designed the website or booked tickets and hotels. All this was managed by the capable organization of WouterV, DenickM and MaartenS. In a previous Vonk, we already have shown some of the projects we have been working on, and all this work has enabled us to go on this amazing journey.

And so it was the 7th of September that we found ourselves in an airplane to our country of destination: China! This is one of the most interesting countries for Electrical Engineers to visit, both for its history as a major producer of electronics, as well as its recent focus on research and development. Our trip would take us all along the east coast, since that is where most of the industry is located, from starting point Beijing to Nanjing, Shanghai, Shenzhen and finishing point Hong Kong.





When we arrived in Beijing, our trip had already reached full speed, with a visit to the Forbidden City immediately after check-in at our hotel, which was conveniently located near the Tiananmen Square in a street full of little shops and street food. The Forbidden City is indeed a city, as we found out after the nth square with temples. As expected this would not be the only time that the magnitude of things in China caused amazement and wonder. Everything in Beijing could be considered 'level Asia', from the large number of people to the size of the temples and buildings, to the uncountable LED advertisements in all sizes and shapes in front of souvenir shops and fake electronics. Especially at night, the city was vibrant with people going out and we often found ourselves enjoying cheap beers in the local bars. Our supervisor Tom did not have any

trouble finding some English girls in the hotel to drink with, and of course the night ended way too late.

The next couple of days we spent visiting some cultural highlights, such as the Summer Palace and of course the Great Wall, which was as impressive as one could imagine from the media. However, we did not only come to China to go on a holiday, which is why after the weekend we visited the first companies, amongst which were the Tsinghua university (no 1 in China), Lenovo and Nokia. Most of the large companies are less interesting than one might imagine, since we never got to see their production sites or research departments. Rather we got a tour around a 'museum' and an intro of what the company is about. However, the universities that we visited were a lot more open. We had several interesting

opportunities to discuss and converse with Chinese students, in order to find out how they experienced student life, as well as some interesting presentations of their research, for example image recognition in security camera's, artificial fish robots (which looked very realistic) and inductive power coupling in medical appliances.

After four days in Beijing we took the bullet train to the city of Nanjing. The train departed around 16.00, which seemed to us a suitable time to start the first beer of the day. After having emptied the fridge of the train (either that, or we were not allowed any more beer), we arrived at another gigantic train station hall, which seemed to have been built especially for prestige, as it was almost deserted. Later we heard that it is the world's second largest train station in





terms of floor area, which does not surprise me. Our hostel in Nanjing was located in a less central place than the one in Beijing, which meant some of us had a bit of trouble getting there (especially Jelle with his bulky suitcase that had no wheels or handles). The rooms in the hostel also were a lot smaller, but we were only staying for two nights. Besides, most days we were so tired that we could sleep anywhere. The reason for our visit to this city was that the university of Nanjing has a high esteem of Bram Nauta, who was supposed to accompany us but eventually couldn't due to visa issues. However, even with their 'god' absent, we were received very well by prof. Wang, who showed us around their new campus (once again, ginormous). The university had some 200.000 students, of which 2000 EE students enrolled annually. We wondered how on earth we were ever going to get a job with so much competition, but as a Chinese professor said, they work harder but only when told what to do, whereas our 'kenniseconomie' has made us independent. However, this difference is ever decreasing, due to the strong development of Chinese intellect.

After a tour around the old campus and another delicious lunch, we headed to Linggu Scenic Area, which is a large park surrounding a number of Buddhist temples and pagodas. As usual, the weather was hot but not sunny, so our photo's are always a little more grey than the ones in travel guides. However, the park offered some nice views and a relaxed afternoon. In the evening, we separated in small groups for din-

ner, and tried to tick off some of the items on our food bingo card, for example turtle, toad or century egg.

The next morning we headed back to the railway station to travel to Shanghai, where we were to stay in the most luxurious hotel of the trip, the SSAW hotel. Even though there was no swimming pool the beds were heavenly soft. Most of us used the time to rest a bit, since the travelling, visits and new impressions left most of us satisfied but exhausted at the end of every day.

The first company visit in Shanghai was Philips, where we enjoyed a Dutch presentation from the CTO. We also visited the lighting R&D department and took an illegal look inside their laboratory (the enthusiastic guide forgot to mention that photographing wasn't allowed). That evening was the first time I went to a Chinese club (the other

nights we only went to bars), which was quite the experience, since clubs in China are very different from disco's in Holland. Here every group has their own table and people spend their time playing dice games while drinking a mix of whiskey with ice tea (when we were offered to drink with some Chinese people, we found out that the ratio whiskey/ice tea was so low that it was better to stick with beer). Occasionally, a couple of dancers would enter the stage and perform, while at other times the stage was occupied by random singers doing covers of popular songs (of course 'Gangnam Style' was our favorite). All of this was very amusing and during the rest of the trip we visited many more clubs.

The next day we went to the tailor market, where several people had their own tailored suit made. Following this excursion, we went cycling through downtown Shanghai.





This was quite an experience, since the traffic in China is based on how confident you cross a street. Green lights are actually orange and red is simply a dark shade of green, which means that you can cross at any time, as long as you look confident enough or ring your bell loud enough. The skyline of Shanghai is amazing to see, but we knew that later on, we were going to enjoy it even more. That night we had to say goodbye to our supervisor Tom, but not before visiting a comedy show.

The next day we moved to a slightly less luxurious hostel, which was nevertheless rather pleasant to stay in. From there, we went to a fishing town that was similar to Giet-hoorn, but again 'level Asia'. In the evening, we visited the top floor of the Hyatt hotel to enjoy the skyline of Shanghai at night while enjoying the comfort of a hot tub. Of course there were also quite a few companies to visit, amongst which was Tecnotion, a manufacturer of linear motors. Our contact there was Dutch and also had organized trips to some of their suppliers, including a local PCB manufacturer, where we could walk around freely and check out the etching and testing facilities. Luckily we had Xiaojing with us, because none of the staff could speak English, so her translations were often very welcome. Other company visits in Shanghai were Eaton (UPS, Fuses,



Hydraulic pumps, etc.), Fudan University, HP and Mintai Hydraulics, where we were also invited for dinner. We also visited the observatory in the Shanghai World Financial Centre, which is the world's second highest.

The last evening in Shanghai was the night of my birthday, which meant some partying in a Shanghai club. Therefore, it was extra difficult to get up the next day. However, it was time to leave for the next city, Shenzhen, this time by plane. Upon arrival, we were greeted by hostess Vicky, who brought a bus fit for 24 people, but not for 24 people with luggage. After a demonstration of

our spatial insight, we were able to fit everything in, although the Dutch police would have taken us off the road if they'd seen us. In Shenzhen, we visited Seed Studio's, which is an open-source hardware facilitator, meaning they give you the possibility for producing your own hardware design. In reality, their Arduino developer's kits are their biggest product. We also visited Huawei, which is now the world's largest telecom company. Furthermore, we went to two manufacturers of LED displays (the ones you see hanging on the side of a building), Yaham and Retop. Yaham greeted us with a committee of their foreign sales department, which we were all pleasantly

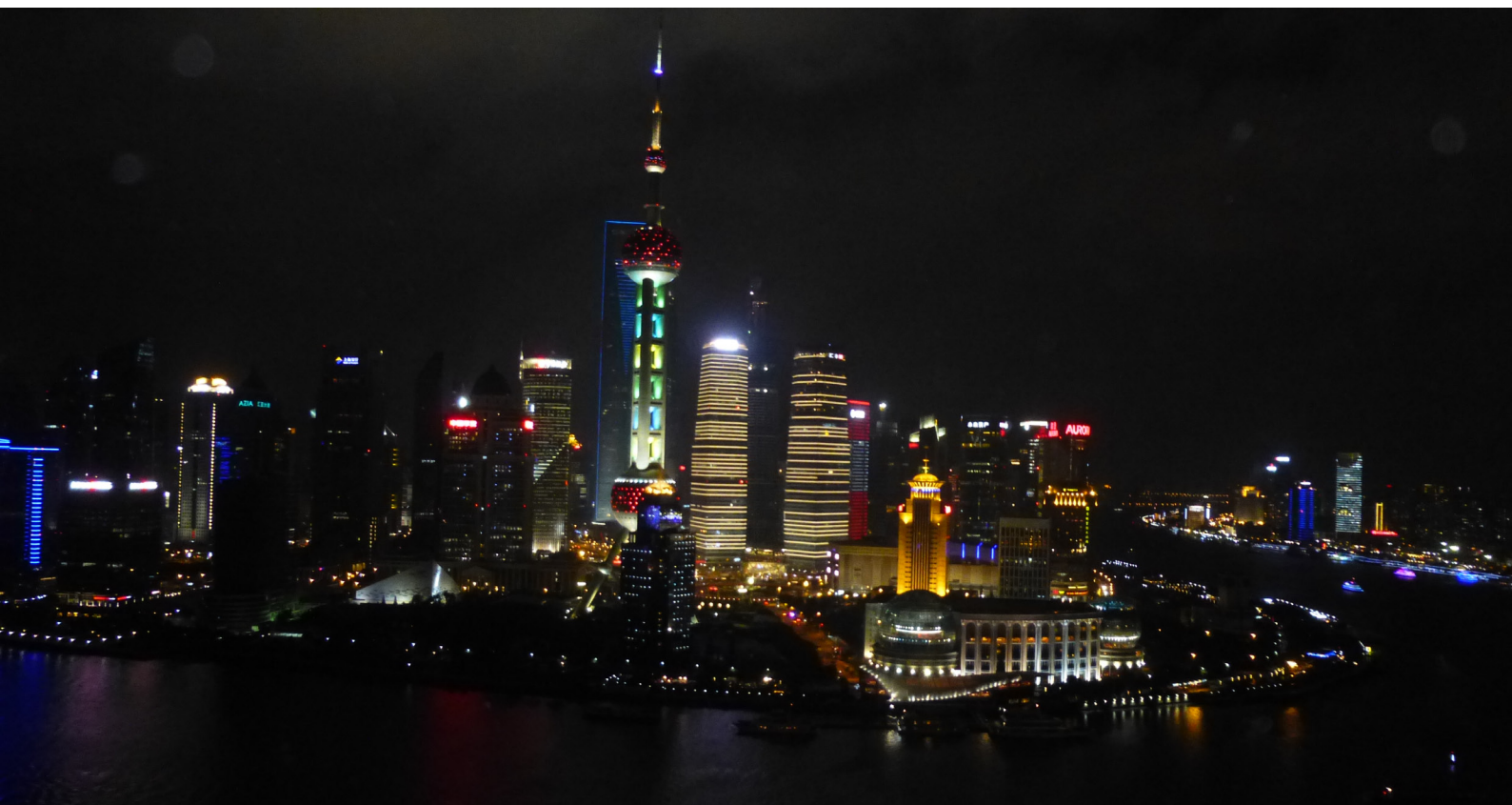



surprised by. It also turned out that they had provided the LED screen in the Grolsch Veste. Both companies led us around their production site, where Chinese girls were soldering the PCB's together and testing the screens by hand.

Shenzhen also has a large community of expats, people who came from different countries to work and live in China, and we went to one of their parties to chat with them about life in China and how they experienced it here. Afterwards, most of us went on to one of the neighboring clubs.

Shenzhen is mostly known for its industry, with large manufacturers of electronics located there. These electronics are sold in a



large electronics market, the SEG market, which we visited of course. Since there are also a lot of Japanese brands in production in China, there had been some riots around the market in the days before, but we were told that the area was safe again. However, we did see quite a large police force patrolling the site.

The SEG market is a building 11 stories high, fully loaded with small electronics shops, with every kind of electronics you can think of. The hobbyists among us were able to buy cheap components, while others tried to find new phones (fake brands were everywhere), tablets and other gadgets, but there were also computer divisions and audiovisual shops with TV's and HiFi audio. We were only there for an afternoon, but I bet that most of us could have stayed for days because there was so much to see. Scheduled on the last night in Shenzhen was the cantus, which for this occasion took place in a karaoke bar. The employees were a little bit overwhelmed by the 25 people who were dressed in weird garments and

suits and who apparently didn't need a TV screen to sing songs. They also found the order of 100 beer cans a little bit strange, but were very eager to help us and serve us what we wanted, and in the end the cantus was very successful. Afterwards, the TV was turned on for some real karaoke, and the night ended with some of us visiting the nearby club.

The following day we traveled to Hong Kong by ferry, where we also met our new supervisors, Wilfred van der Wiel and Leimeng. The hostel that we stayed in is placed in Mong Kok, which is the area with the highest number of inhabitants per square meter in the world. This also became clear when we saw our rooms, with only a small bathroom (you had to sit on the toilet to take a shower) and too many beds in one room at the 26th floor. However, we were gone most of the time so none of us really minded this.

The first day in Hong Kong started with a tour around the city. We saw the nice skyline from Victoria Peak, as well as the

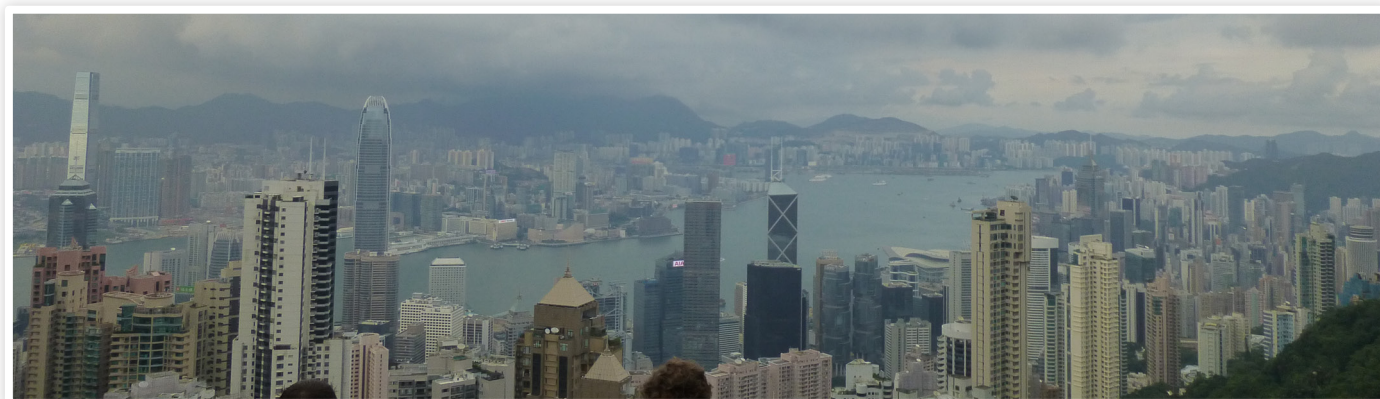



beaches and the boulevard with a hall of fame for Chinese martial arts film stars. Off course we also had a nice dinner (once again) and went out to the local bar street. Scheduled company visits in Hong Kong included the consulate of the Netherlands, the Hong Kong University of Science & Technology (which had a library with a view over the pacific ocean), Convenient-Power (who developed a wireless power transfer for charging mobile networks, their system was already in use by Nokia, HTC,

Samsung and more), and Cypress Systems, a company that provides home solutions for light switching and home automation.

As the study tour was approaching its end, there was more time for some cultural activities, such as an evening boat tour through Victoria Harbour and a nice tour to a local island where we could swim and drink, where we also had a BBQ on the beach. The last day on the schedule was a trip to Macau, which is the Chinese version of Las Vegas,

but this city has even more casino's. During the trip we saw some of the Portugese heritage as well as some of the largest casino's. After this trip it was time for some of us to say goodbye and for others to embark on a holiday. All in all, the trip was amazing. China is an amazing country and the organization of this trip was almost flawless. I was glad to have been a part of this project and already look forward to the next trip.



# Baking Pies – Part 1

Meet the credit-card-sized electronic fruit

*Author: Peter Oostewechel*

In this 4 part series we will cover some use cases for the Raspberry Pi, both hardware and software. In part 1 of this series, a general introduction to the Raspberry Pi is given. The Raspberry Pi is a credit-card-sized single-board computer developed in the UK by the Raspberry Pi Foundation with the intention of stimulating the teaching of basic computer science in schools. The average Electrical Engineering student is most likely very interested in this small device. As a user you are able to hook up your own peripherals and electronic creations, choose your own operating system and free to use it however you want. Available for about €40 at the STORES, it almost sounds too good to be true. Let's find out if it is.

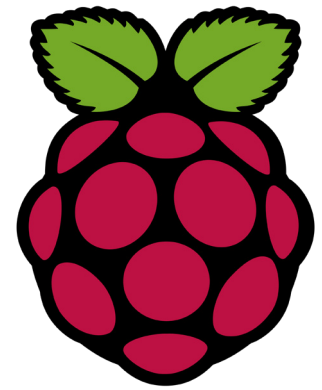

## History

The Raspberry Pi is a project with a long history: as far back as 2006 Eben Upton (the lead designer of the Raspberry Pi) was using the experience he gained at his day job as an engineer for system-on-chip specialist Broadcom to develop a perfboard-based prototype with a Atmel ATmega644 microcontroller running at just 22.1 MHz and with 512 KB of RAM.

Some Electrical Engineering students may be familiar with microcontrollers. While microcontrollers are fine for prototyping

projects like the Arduino and its clones,

---

“I felt that much higher performance, and the ability to run a general-purpose operating system, outweighed the benefits of home assembly.”

---

Upton and his colleagues had something a little more powerful in mind. ‘In the end,’ Upton wrote of his original prototype, ‘I felt that much higher performance, and the ability to run a general-purpose operating system, outweighed the benefits of home assembly.’ That’s why the Raspberry Pi is a neat alternative for the more processing power intensive prototyping applications.

With the aid of components provided by Upton’s employer Broadcom, the pair founded a charitable entity with a noble goal: to build computing devices at such a low cost that every child could afford one, potentially making a massive difference to the teaching of computer science both in the UK and throughout the world. All this led to the much more powerful Raspberry Pi available today.

## Hardware

The only Raspberry Pi on sale is the Model B with two USB ports and a 10/100 Mb Ethernet controller. The Ethernet port of the model B is a built-in USB Ethernet adapter. This means that the Ethernet chip is connected directly to the USB interface on the Broadcom chip. The full system features are listed in the table.

The Raspberry Pi does not come with a real-time clock, so an OS must use a network time server, or ask the user for time information at boot to get access to a time and date for file time and date stamping. However, a real-time clock (such as the DS1307) with

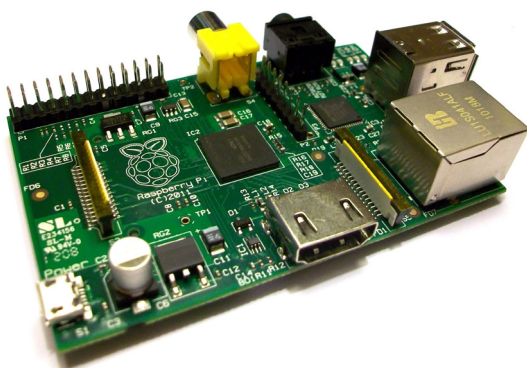

| Model B                       |   |
|-------------------------------|---|
| <b>System-on-a-chip (SoC)</b> | Broadcom BCM2835 (CPU + GPU + SDRAM)  |
| <b>CPU:</b>                   | 700 MHz ARM11 ARM1176JZF-S core   |
| <b>GPU:</b>                   | Broadcom VideoCore IV<br>OpenGL ES 2.0<br>OpenVG 1080p30 H.264 high-profile encode/decode |
| <b>Memory (SDRAM)</b>         | 256 MB (until 15 Oct 2012)<br>512 MB (since 15 Oct 2012)                                  |
| <b>USB 2.0 ports:</b>         | 2 (via integrated USB hub)  |
| <b>Video outputs</b>          | Composite video   Composite RCA<br>HDMI (not at the same time)                            |
| <b>Audio outputs</b>          | TRS connector   3.5 mm jack<br>HDMI   |
| <b>Audio inputs</b>           | None, but a USB/ I <sup>2</sup> S mic or sound-card could be added                        |
| <b>Onboard Storage</b>        | Secure Digital   SD / MMC / SDIO card slot  |
| <b>Onboard Network</b>        | 10/100 wired Ethernet RJ45  |
| <b>Low-level peripherals</b>  | GPIO pins, SPI, I <sup>2</sup> C, I <sup>2</sup> S, UART                                  |
| <b>Real-time clock</b>        | None  |
| <b>Power ratings</b>          | 700 mA, (3.5 W)   |
| <b>Power source</b>           | 5 V (DC) via Micro USB type B or GPIO header  |
| <b>Size</b>                   | 85.0 x 56.0 mm  |

battery backup can be added via the I<sup>2</sup>C interface. For us as Electrical Engineering students adding one should not be a problem and is a nice challenge, you can even get a nice RTC-module at the STORES. For the people that are interested in the layout, the schematics were released by the Raspberry Pi foundation[1].

Hardware accelerated video (H.264) encoding became available on 24-Aug-2012 when it became known that the existing license agreement also covered encoding. Previously it was thought that encoding would be added with the release of the announced camera module.

At the same time the Raspberry Pi Foundation released two additional codecs that can be bought separately, MPEG-2 and Microsoft's VC-1. The Raspberry Pi also supports CEC, enabling it to be controlled with the television's remote control.

## Software

The Raspberry Pi uses Linux kernel-based operating systems. The full featured system Raspbian, a Debian-based free operating system optimized for the Raspberry Pi hardware, is the current recommended operating system. In addition, work is being

done on system specific light Linux distributions such as IPFire (A router distribution), Instant WebKiosk (A web browser only distribution) and OpenELEC, Raspbmc and Xbian (XBMC based mediacenter distributions).

The hardware is accessed via a firmware image which is loaded into the GPU at boot time from the SD-card. The firmware image is known as a binary blob. The binary blob also loads the Linux kernel which takes over the boot process. The whole ARM userland has been released as free software under a BSD-style license, making it 'the first ARM-based multimedia SoC with fully-functional, vendor-provided fully open-source drivers'. So if you feel especially adventurous you can also play with the low level drivers.

This concludes part one of this series, hopefully you'll now have a basic understanding of what the Pi is capable of. In the following parts of this series we will discuss a use case with XBMC, general purpose and the Raspberry Pi as electronics and prototyping platform. If you have any questions, suggestions or remarks about this series please contact the author.

[1] Raspberry Pi schematics, <http://www.raspberrypi.org/archives/1090>

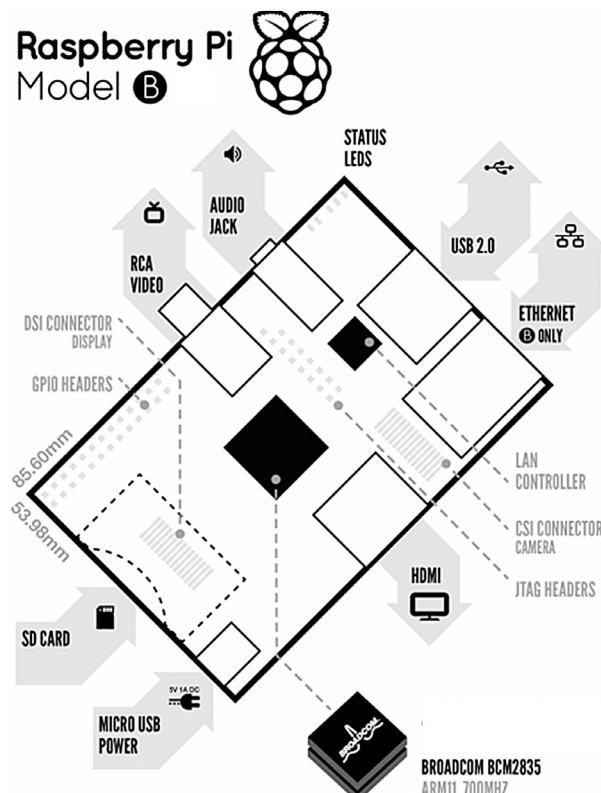

# Righting wrongs

*Author: Marcel Wenting*

There are many wrongs in this world and most of them man-made. Some of them are solvable, others have already done irreparable damage. It all started of course when the Greek titan Prometheus gave man fire. For due to the power of fire man developed and so it came to be that there was science. The beginnings of which were focused on thought and deduction, only later math was invented. This, as we all know, turned out to be both a blessing and a giant pain in the ass.



You see, math at its core is a fine concept. You define some numbers, set some axioms and you're ready to start calculating your way from a straight line to the angular momentum of fermions.

However, somewhere along the way the purity of math was defiled by pride. For there is no logical reason to have a set of physics equations so riddled with constants as ours. We as a species do not deserve to exist if we cannot come up with some better units that don't need ten digit constants to convert to each other.

But possibly more annoying is the overwhelming urge of the scientific community at large to honour long dead geniuses by naming these constants or formulae after them. Why do people who claim to do a profession of logic feel the need to do such a highly illogical thing? Don't tell me that nobody on this planet couldn't come up with a better name for the formula that describes the Spin-Transfer-Torque effect than the Landau-Lifshitz-Gilbert equation.

It is a sad fact that for generations students have to learn these ridiculous names and enter way too many numbers on their calculators just to honour the drug-induced insight of some guy sitting under a tree watching an apple fall. I mean, you would think that a Nobel prize would be enough.

Fortunately some engineers are not afraid to admit their mistakes. The inventor of the web standards, Tim Berners-Lee, publicly apologized a few years ago for making the whole world type `('//'` after `'http:'`, for which he should be truthfully sorry.

---

*"We as a species do not deserve to exist if we cannot come up with some better units"*

---

My hope now is that whoever thought it was a good idea to invent glossy screens is next. He or she will admit putting the world through agony tilting screens, adjusting seats and changing lights until finally giving up because there's no way to get rid of the all present glare of lights and your own reflection just on the spot where you want to read. After which the tech industry will come to its senses and stop ruining otherwise perfect devices with these unnecessary, impractical and annoying screens.

# Puuzle

*Author: Truusje*

An old Chinese saying teaches us that 一分耕耘,一分收获, translated to 'if one does not plow, there will be no harvest'. Replace 'plow' by 'solve puuzles' and 'harvest' by 'cake', and you get my message.

The previous puuzle was successfully solved by several people, but the amount of entries makes me doubt the analytic capabilities of the young EE division these days (or did I make it too difficult for you?). Anyway, I may congratulate Geert Folkertsma this time with submitting the winning solution. One of my minions will contact you and deliver the famous Vonk-cake.

You can send your solution to [truusje@scintilla.utwente.nl](mailto:truusje@scintilla.utwente.nl), or deposit it in the Vonk mailbox in the SK.

Good luck and enjoy!



*Rick was happy to receive a cake for his correct solution of the Nurikabe*

This time, I've selected yet another puuzle of Japanese soil. This puuzle is called 'slitherlink', and slightly resembles 'minesweeper'. The game field consists of a lattice of dots. Some of the squares formed by the dots have numbers inside them. The objective is to connect horizontally and vertically adjacent dots with the goal to form a simple loop with no loose ends using the lines. In addition, the number inside a square represents how many of its four sides are segments in the loop.

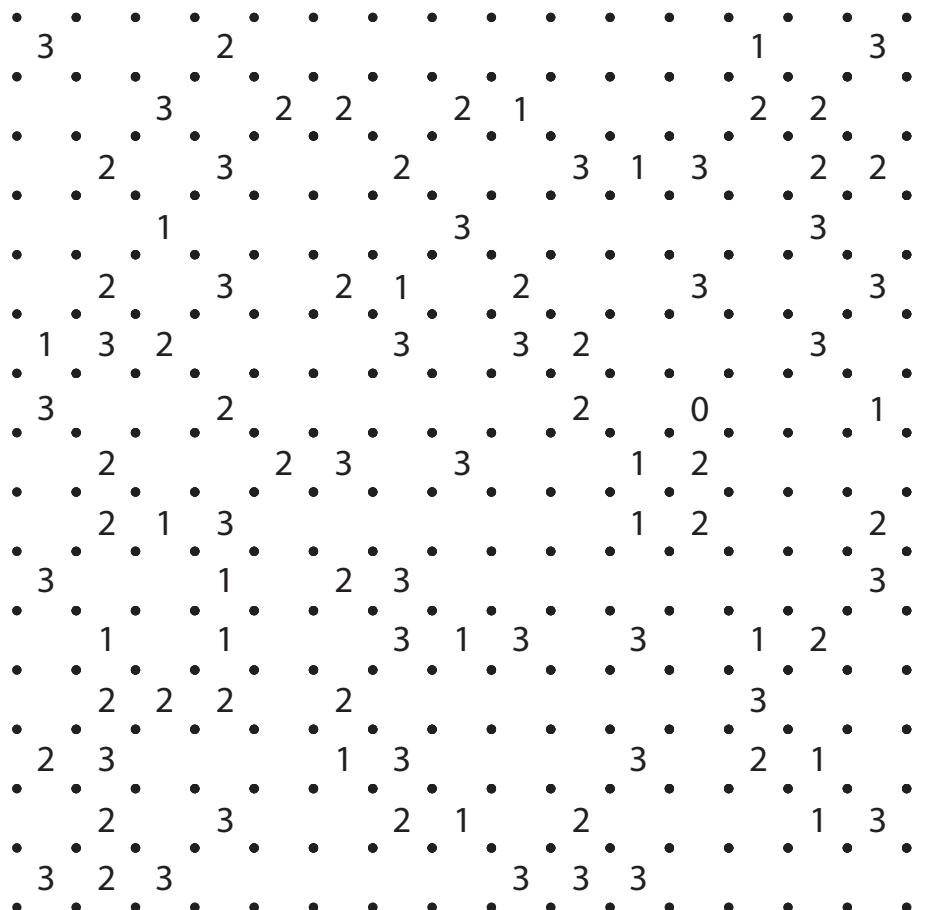

>topteams  
in Gouda

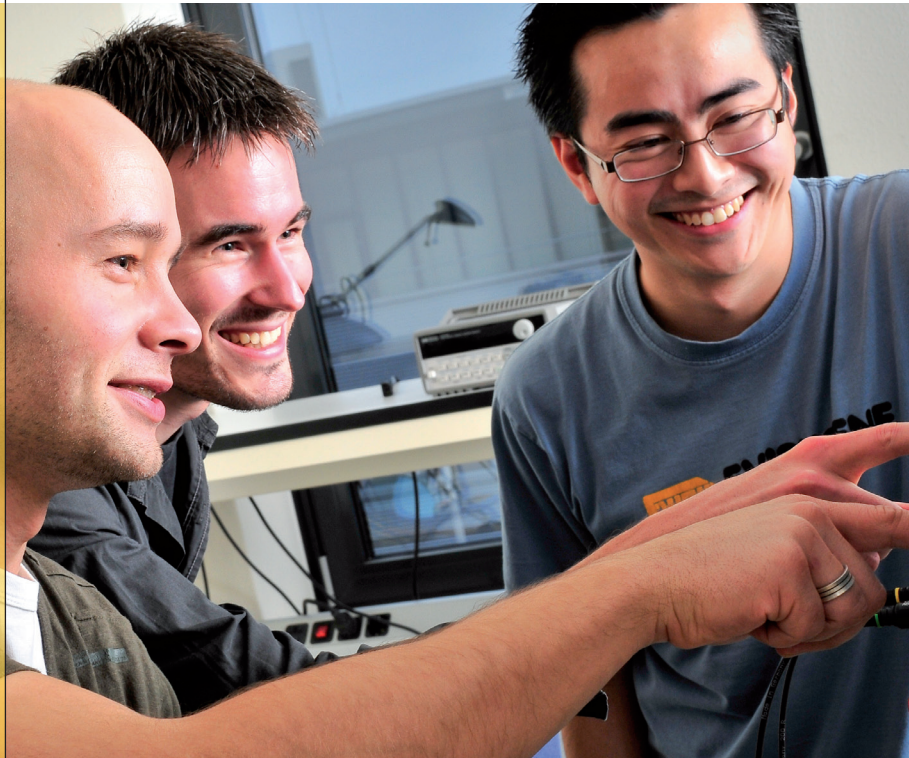

>dieptechnologisch

Bij ons werken toppers. Toppers met een afgeronde studie electrical engineering of computer science. Samen werken zij aan projecten voor onze klanten. Elk projectteam wordt samengesteld gebaseerd op de talenten en ambities van onze collega's. Zo bereiken wij het meest optimale, voor onszelf en voor de klant. Wij vinden dat heel logisch.

[www.technolution.eu/carriere](http://www.technolution.eu/carriere)

